

Maximum Power Point Tracking for Wind Energy Conversion System

Omessaad Elbeji^{#1}, Mouna BenHamed^{*2}, Lassaad Sbita^{#3}

[#]Department of electric automatic, National Engineering School of Gabes
Address Including Tunisia

¹omessaadbeji@hotmail.fr

³lassaad.sbita@enig.rnu.tn

²benhamed2209@yahoo.fr

Abstract — in this work an optimal control scheme based on the Maximum Power Point Tracking for the Wind Energy Conversion System using Permanent Magnet Synchronous Generator was proposed. In fact, the wind turbine was modelled. It was controlled with Tip Speed Ratio MPPT approach. Then the generator was controlled with vector control strategy. The overall system was simulated with MATLAB/SIMULINK.

Keywords— WECS, PMSG, MPPT, TSR, AC/DC converter

I. INTRODUCTION

Nowadays, the world needs to look at the different available natural energy sources. In fact, our energy craving lifestyle can result global warming. Different researchers and scientists look into more environmentally friendly energy sources. Wind energy generates electricity without burning fossil fuels; it is friendly to the surrounding environment [1].

Wind energy conversion system has also many advantages. Firstly, to producing electricity wind energy doesn't require fuel, doesn't create greenhouse gas emissions, and doesn't produce toxic or radioactive waste. Secondly, wind energy produces wind power: without degrading the quality of air, neither polluting the water nor polluting the soil. Then, when large wind farms are installed on farmland, only about 2% of the land required for wind turbines. The remaining area is available for farming, livestock and other uses [1].

However, wind energy is dependent on topography, weather and environment. It's necessary to choose the best place where the quality of air can produce more electricity. Then, it's difficult to wind turbine to provide 60% of the power wind speed. Wind Energy Conversion System (WECS) have also other loss factors like mechanical friction and low generator's efficiency. So the amount of power output from WECS depends to the tracked wind power. Therefore, a maximum power point tracking (MPPT) control is required [2].

In order to achieve the maximum power control, many researches are carried out. So with an MPPT strategy WECS has good performance. There are many algorithms of MPPT; the most used one is the Tip Speed Ratio (TSR) strategy that tracked the maximum power point with control of speed torque. It has several advantages such as simplicity of

implementation, fast convergence speed, and it has high performance under varying wind condition [3].

Therefore, selecting generator has also an effect on the WECS performance. In this work, a Permanent Magnet Synchronous Generator (PMSG) is used in WECS due its higher performance, high efficiency and reliability, since there is no need of external excitation and conductor losses are removed from the rotor [2-5].

This paper proposes a control structure of wind energy conversion system equipped with permanent magnet synchronous generator witch based on maximum power point tracking using tip speed ratio strategy.

This paper is organized as following; in the first section the overall system are configured witch define the wind turbine model, the PMSG model. The MPPT control strategy was described in the second section. The third present the vector control strategy and its different regulators.

Simulations results with MATLAB/SIMULINK are carried out, in the forth section, to prove the performance of the used MPPT control and the different blocs of WECS. Finally some conclusions are given in the last section.

II. WIND ENERGY CONVERSION SYSTEM CONFIGURATION

Wind energy conversion system that defined in Fig. 1 is composed by the wind turbine, a generator and a converter. In fact, the wind turbine converts the wind power to a mechanical energy that converted in an electric energy by the wind generator. The AC/DC converter that is modelled by a thyristor rectifier converts the alternative electric signal into continuous one [5-6].

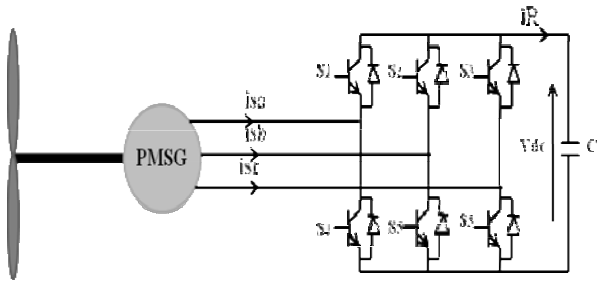

Fig. 1. Wind energy conversion system configuration

A. Wind turbine modelling

The output power of a wind turbine is defined as:

$$P_t = \frac{1}{2} \rho R \pi v_w^3 C_p(\beta, \lambda) \tag{1}$$

Where R is the turbine radius, ρ is air density, v_w is the wind speed, and C_p is the power coefficient that given by [7-9]:

$$C_p(\beta, \lambda) = 0.5176 \left(\frac{116}{\lambda_i} - 0.4\beta - 5 \right) \exp^{-\frac{21}{\lambda_i}} + 0.0068\lambda_i \tag{2}$$

Where β is the pitch angle and λ_i

$$\lambda_i = \frac{1}{\frac{1}{\lambda + 0.08\beta} - \frac{0.035}{\beta^3 + 1}} \tag{3}$$

The tip speed ratio is given by:

$$\lambda = \frac{\Lambda R}{v_w} \tag{4}$$

With Λ is the turbine speed

The mechanic model of the wind turbine is described by [6]:

$$J \frac{d\Lambda}{dt} + f\Lambda = T_t - T_{em} \tag{5}$$

Where, f is the turbine rotor friction T_{em} is the electromagnetic torque, and T_t is the turbine one and given by:

$$T_t = \frac{P_t}{\Lambda} \tag{6}$$

B. PMSG model

A permanent magnet synchronous generator can describe in the d-q reference by the following equations system [9]:

$$\begin{cases} \frac{di_d}{dt} = -\frac{R_a}{L_d} i_d + \frac{L_q}{L_d} p\Lambda i_q + \frac{1}{L_d} u_d \\ \frac{di_q}{dt} = -\frac{R_a}{L_q} i_q - \frac{L_d}{L_q} p\Lambda i_d - \frac{1}{L_q} p\Lambda \phi_m + \frac{1}{L_q} u_q \end{cases} \tag{7}$$

Where R_a is the armature resistance; L_d, L_q are the generator inductance; i_d, i_q are current components; u_d, u_q are the voltage components, p is the pole pairs number and ϕ_m is the permanent magnet flux.

III. MAXIMUM POWER POINT CONTROL STRATEGY

It's necessary to regulate the turbine power to extract a maximum wind power. The turbine power P_t is depend to the wind speed v_w and the power coefficient C_p . In order to maximise the turbine power, we have to research the optimum one. In other side, v_w isn't controllable it's necessary to search the optimum power coefficient C_{p_opt} that varied depending on the tip speed ratio λ . So C_{p_opt} is given by a optimum tip speed ratio λ_{opt} that also depends on the turbine speed Λ .

$$\text{Where } \lambda_{opt} = \frac{\Lambda_{opt} R}{v_w} \tag{8}$$

A. TSR Maximum power point strategy

The wind power speed is maximum at Λ_{opt} which corresponds to λ_{opt} . In order to have maximum possible power, the turbine should always operate the optimum tip speed ratio (TSR strategy control). This is possible by controlling the rotational speed of the turbine so that it always rotates at the optimum rotation speed Λ_{opt} [1-5].

The TSR control method regulates the rotational speed of the generator in order to maintain the TSR to an optimum value at which power extracted is maximum. This method requires both the wind speed and the turbine speed to be measured or estimated in addition to requiring the knowledge of optimum TSR of the turbine in order to extract the maximum possible power. Fig. 2 shows the block diagram of a WECS with TSR control.

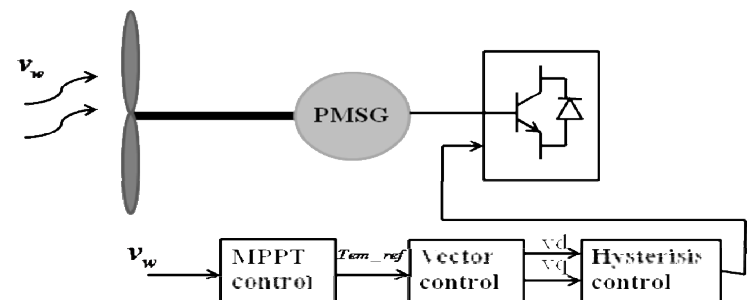

Fig. 2. Overall studied WECS with TSR strategy

B. MPPT controller

The fluctuating behavior of the wind speed caused some variation in the WECS. So the electromagnetic torque is assumed at the reference one irrespective of the generated power.

$$T_{em} = T_{em_ref} \quad (9)$$

In order to have an optimal speed control, the following scheme is implemented:

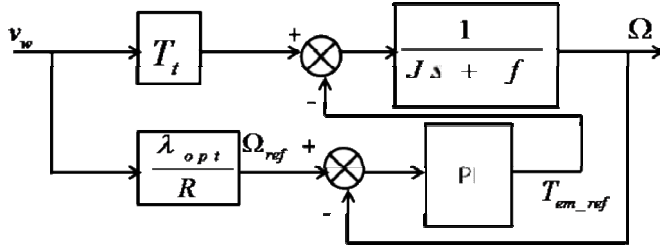

Fig. 3. Speed Control with MPPT strategy

According to Fig. 3 the electromagnetic Torque is the output of a PI controller that regulates the wind speed. The transfer function of this control is :

$$T_{em_ref}(s) = (\Lambda_{ref}(s) - \Lambda(s))(K_p + \frac{K_i}{s}) \quad (10)$$

C. Vector control strategy

The main purpose of a vector control strategy is to maintain the quadrature component current null ($i_d = 0$) field orientation [10-11].

Two current controllers are created to prove the performance of the control strategy.

The flux is controlled indirectly by longitudinal component of current. The torque is controlled indirectly by quadrature component of current. We use two similar PI controllers for the two current as in Fig. 4

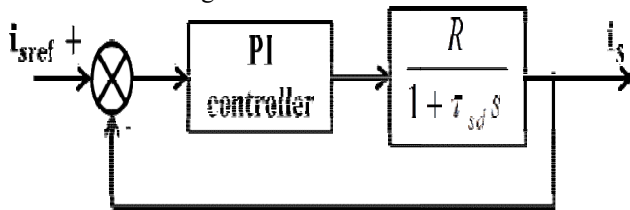

Fig. 4. Current loop control

D. Rectifier model with hysteresis control

A rectifier is a AC/DC converter that convert the alternative component into continuous one. It can be controlled or uncontrolled. A controlled rectifier is composed for transistors however the uncontrolled one is composed by diodes [12].

IN this paper, a controlled rectifier is modelled and controlled. It is follow in Fig. 5

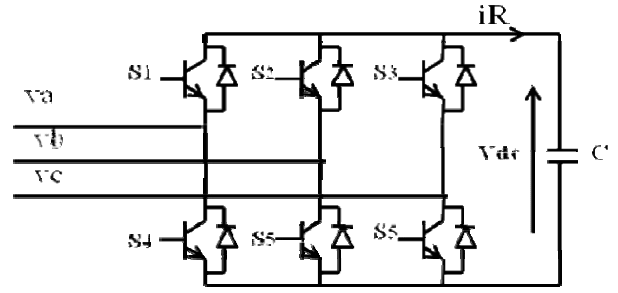

Fig. 5. Controlled rectifier

The rectifier model can be facilitated and reduce the simulation time by modelling the rectifier with ideals switches. Ideal switches are defined as:

$$\begin{cases} S_j = +1 \\ S_j = -1 \end{cases} \quad j = a, b, c \quad (11)$$

Input voltages between phases of the rectifier can be written by:

$$\begin{aligned} U_{S_{ab}} &= (S_a - S_b)V_{dc} \\ U_{S_{bc}} &= (S_b - S_c)V_{dc} \\ U_{S_{ca}} &= (S_c - S_a)V_{dc} \end{aligned} \quad (12)$$

Then, the voltage system equations can be written as:

$$\begin{bmatrix} V_{sa} \\ V_{sb} \\ V_{sc} \end{bmatrix} = R \begin{bmatrix} I_{sa} \\ I_{sb} \\ I_{sc} \end{bmatrix} + L_s \frac{d}{dt} \begin{bmatrix} i_{sa} \\ i_{sb} \\ i_{sc} \end{bmatrix} + \begin{bmatrix} U_{Sa} \\ U_{Sb} \\ U_{Sc} \end{bmatrix} \quad (13)$$

Where,

$$\begin{aligned} U_{Sa} &= \frac{2S_a - S_b - S_c}{3} V_{dc} \\ U_{Sb} &= \frac{2S_b - S_c - S_a}{3} V_{dc} \\ U_{Sc} &= \frac{2S_c - S_a - S_b}{3} V_{dc} \end{aligned} \quad (14)$$

Finally, the equation related the input current, the continuous output current, the switches states and the continuous output voltage is described by [12-14]:

$$c \frac{dv_{dc}}{dt} = (S_a i_a + S_b i_b + S_c i_c) - i_{dc} \quad (15)$$

IV. SIMULATIONS RESULTS

The complete WECS with PMSG was simulated by Matlab/Simulink. The block diagram of the complete wind

speed variable speed direct drive PMSG WECS is shown in Fig. 6 [15-16]. The proposed method is verified using simulation. The details of the WECS are given in Appendix.

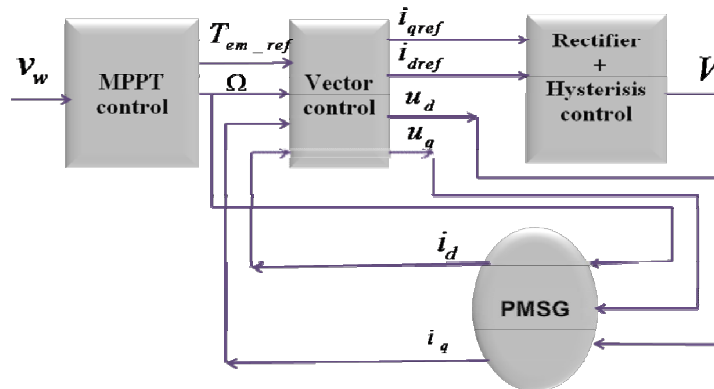

Fig. 6. Overall WECS studied scheme

Simulation Results are given by figures; Fig. 7 to Fig. 16 that prove the performance of the TSR strategy and the vector control. In fact, the tip speed ratio is optimum as desired λ , the coefficient power is in the maximum and also the wind turbine power. The wind speed is completely identical at the reference one. The characteristics of the wind turbine Power during the variations behaviour of the wind speed prove that the MPPT strategy can tacked the maximum power point even in variable speed.

During the simulation, the d_axis command current of the machine side converter control system is set to zero as shown in Fig. 12. That proves the vector control strategy.

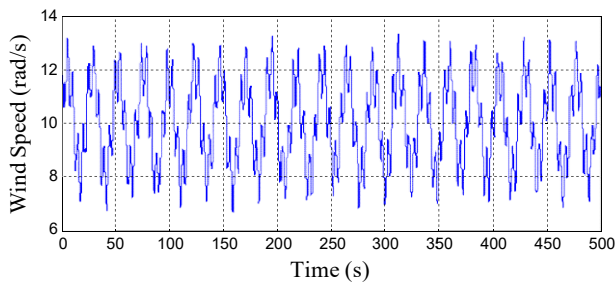

Fig. 7. Wind Speed

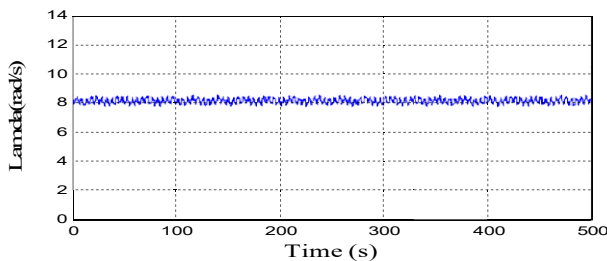

Fig. 8. Tip speed ratio

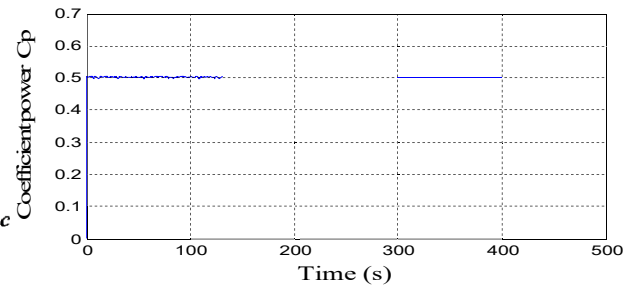

Fig. 9. Coefficient power

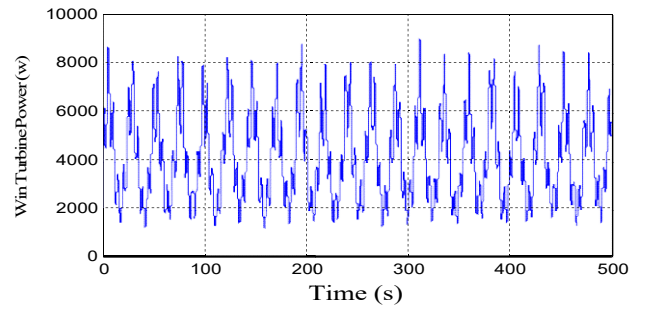

Fig. 10. Wind turbine Power

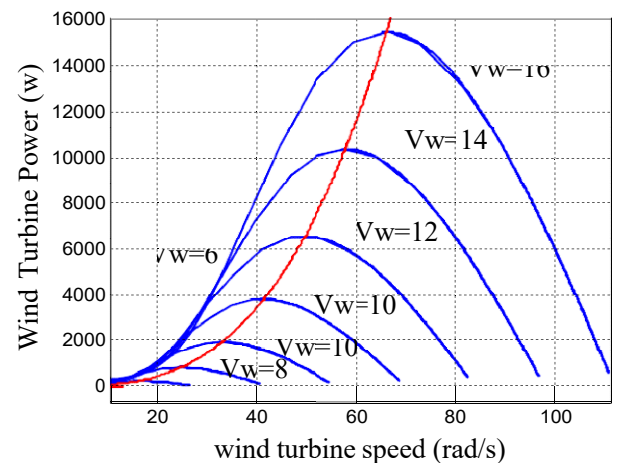

Fig. 11. Wind turbine power with variation of wind speed

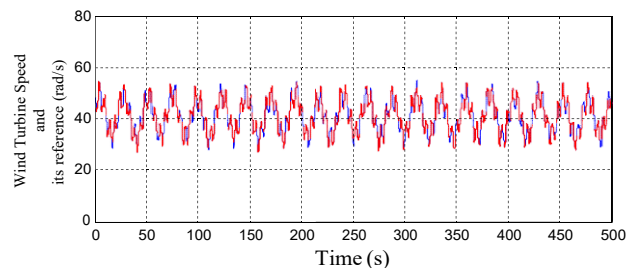

Fig. 12. Turbine wind speed and its reference

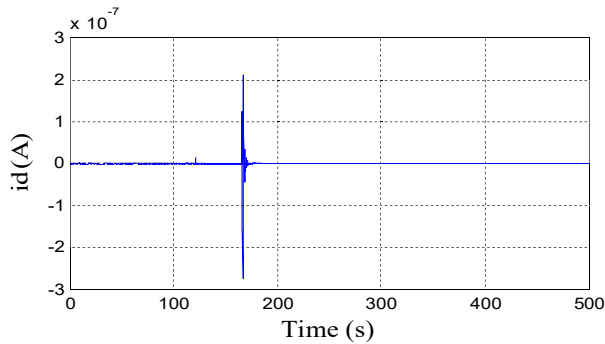

Fig. 13. Direct current component

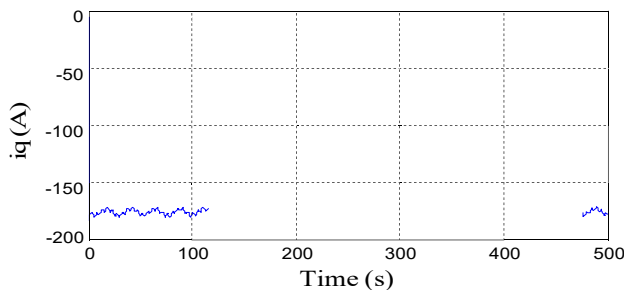

Fig. 14. Quadrature current component

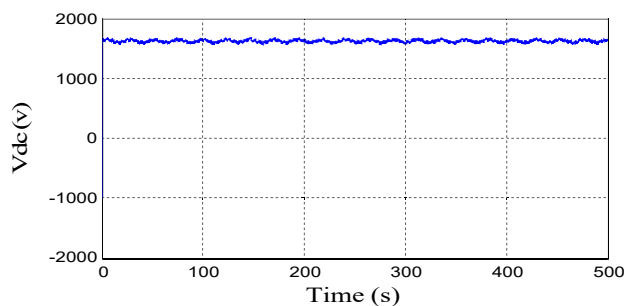

Fig. 15. Continuous voltage (rectifier output)

V. CONCLUSIONS

The variable-speed wind energy conversion system using a permanent magnet generator has been discussed in this paper and the optimal control strategy of PMG maximizing the generated power was proposed. The optimum current value that maximizes output power is determined and used as reference for MPPT algorithm. The control algorithm is made simple from other existing algorithms by this current Speed reference. The system configuration is also simple, but the operation of wind turbine generator is optimized. Simulation study on a Wind Energy Conversion System employing MATLAB/SIMULINK model is the core coverage in this paper.

TSR method tries to modify the rotational speed of generator so as to maintain an optimum TSR. The limitation

of this method is that wind speed needs to be known along with the turbine rotational speed measurements. This adds to the system cost, especially when considered for use with small scale wind turbines. So our future works of this paper the search of a sensorless MPPT controller is will be proposed.

APPENDIX

Parameters of the wind turbine

$$\rho = 1.2 \text{ Kg/m}^3$$

$$R = 2 \Omega$$

$$J = 0.002$$

$$f = 7e-4 \text{ m}^2$$

Parameters of the permanent synchronous generator

$$L_d = 0.0066 \text{ H}$$

$$L_q = 0.0058 \text{ H}$$

$$R_a = 1.4 \Omega$$

$$\phi_m = 0.1546 \text{ Wb}$$

$$p = 3$$

REFERENCES

- [1] J. S. thongam, P. Bouchard, H. Ezzaidi and M. Ouhrouche, "Wind Speed Sensorless Maximum Power Point Traking Control of Variable Speed Wind Energy Conversion Systems", Electric Machines and Drives Conference, pp. 1832-1837, 2009.
- [2] C. K. Sao, P. W. Lehn, M. R. Iravani, et al. "A benchmark system for digital time-domain simulation of a pulse-width-modulated D-STATCOM", IEEE Trans. on Power Delivery, vol. 17, no. 4, pp. 1113-1120, Oct. 2002
- [3] JEONG, Hae Gwang, SEUNG, Ro Hak, and LEE, Kyo Beum, "An improved maximum power point tracking method for wind power systems," *Energies*, 2012, vol. 5, no 5, pp. 1339-1354.
- [4] Thongam, Jogendra Singh, and Mohand Ouhrouche, "MPPT control methods in wind energy conversion systems," *Fundamental and Advanced Topics in Wind Power*, 2011, pp 339-360.
- [5] Srikakolapu, Jayadeep, and Shailendra Sharma, "Performance Analysis of Grid Integrated Wind Energy Conversion system. using Permanent Magnet Synchronous Generator," *Power and Energy Systems*, 2013.
- [6] KOUTROULIS, Eftichios and KALAITZAKIS, Kostas, "Design of a Maximum Power Tracking System for Wind-Energy-Conversion Applications," *Industrial Electronics, IEEE Transactions on*, 2006, vol. 53, no 2, p. 486-494.
- [7] El Magri, A., Giri, F., Besancon, G., El Fadili, A., Dugard, L., & Chaoui, F. Z., " Sensorless adaptive output feedback control of wind energy systems with PMS generators," *Control Engineering Practice*, 21(4), 530-5
- [8] M. Yin, G. Li, M. Zhou and C. Zhao, "Modeling of the wind turbine with a permanent magnet synchronous generator for integration," *Power Engineering Society General Meeting*, 2007. IEEE, pp. 1-6, June 2007.
- [9] O. Carranza, E. Figueres, G. Garcera and R. Gonzalez-Medina, "Analysis of the control structure of wind energy generation systems based on a permanent magnet synchronous generator," *Applied Energy* 103 (2013), pp. 522-538.
- [10] C. Xianfeng, S. Zhibing, Z. Yingkai, "Mathematic Model and Performance Analysis of PMSM, Based Servo System", *Journal of Mechanism and Electronics*, volume 1, pp.41-43, (2005).

- [11] S.M. Muyeen, A. Al-Durra and J. Tamura, "Variable speed wind turbine generator system with current controlled voltage source inverter," *Energy Conversion and Management*, pp. 2688-2694, 2011.
- [12] Z. QUI, K. ZHOU and Y. LI, "Modeling and Control of Diode Rectifier Fed PMSG Base Wind Turbine," pp. 1384-1388.
- [13] S. NATH and S. Rana, "The modeling and Simulation Wind Energy Based Power System using MATLAB," *International Journal of Power System Operation and Energy Management*, vol. 1, issue-2, pp. 12-17, 2011.
- [14] F. Abdal Rassul Abbs and M. Abdulla Abdulsada, "Simulation of Wind-Turbine Speed Control by MATLAB," *International Journal of Computer and Electrical Engineering*, vol. 2, pp. 912-915, 2010.
- [15] A. El Magri, F. Giri, G. Besançon, A. El fadili, L. Dugard, and F.Z. Chaoui, "Sensorless adaptative output feedback control of wind energy systems with PMS generators," *Control Engineering Practise*, 2012.
- [16] A. G. Sanchez, M. G. Molina, & A. M. Lede, "Dynamic model of wind energy conversion systems with PMSG-based variable-speed wind turbines for power system studies", *International Journal of Hydrogen Energy*, pp. 10064-10069, 2012.