

Modeling & Simulation of SVC Device to Build a Smart Grid of Renewable Energy System.

[Sekhane Hocine]

[Laboratory of electrical engineering of Constantine 1]

[LGEC]

[Constantine], [Algeria]

[hsekhane@gmail.com]

[Labeled Djamel]

[Laboratory of electrical engineering of Constantine 1]

[LGEC]

[Constantine], [Algeria]

[djamel_labeled@yahoo.fr]

Abstract— This paper treats the modeling and control of a famous FACTS "Flexible Alternating Current Transmission Systems" device "SVC" "Static Var Compensator", the simulation of the test power grid and SVC were carried out in interface SIMULINK/MATLAB for both cases where SVC was connected into the system and not, with simulation interval [0-2.2 sc]. The aim of SVC is to improve the powers transits and to regulate the voltage at the bus where it is connected and then the network becomes a smart grid. Some results of simulation are presented in this paper, which shows the effectiveness of compensator SVC used at the reception bus.

Keywords- FACTS, SVC, Power grid, PI regulator, Smart Grid

I. INTRODUCTION

Today we live in the era of electronics and data processing, and all loads are very sensitive to the disturbances which occur on their power supplies: a loss of power supply can cause the interruption of the various production processes in a factory; and in front of consumers who become increasingly demanding by wanting more energy and better quality, the production companies of electrical energy must ensure the provisioning regular of this request, and without interruption, through mesh power grid and inter-connected; and increase the number of power plants, lines, transformers etc, which implies an increase in cost and a degradation of the natural environment. [8] In addition more than the power grid increases more than it becomes complex and difficult to control. And in the absence of sophisticated and adequate control devices, much of problems can occur on this network such as: the transit of the excessive reactive power in the lines, the hollows of voltage between various parts of the network etc...

The fast development of the electronics power had a considerable effect in the improvement of the conditions operating of the network into powerful the control of their parameters by the introduction of control devices known under acronym FACTS: "Flexible Alternating Current Transmission Systems".

The objective of this work is to propose an appropriate solution to optimize the reactive power and the control of the voltage in a real test network through the incorporation of "SVC" device.

II. OPERATING PRINCIPLE OF SVC

In practice there are many versions of SVC's compensators exist on the transmission lines [4], of which we chose the "TSC-TCR" type (Thyristor Switched Capacitor -Thyristor Controlled Reactor) for our work. The SVC injects or absorbs the reactive power in the bus where it is connected so as to satisfy the request for reactive power of the load.

The TCR is composed of a reactance placed in series with two thyristors assembled in antiparallel. [3-1]

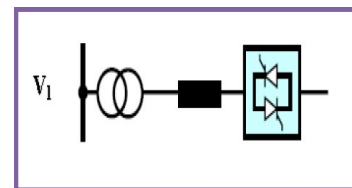

Figure 1. Structure of TCR.

The thyristors are engaged with a certain switching angle (α) and lead alternatively on a half-period. [7] If $\alpha = 90^\circ$ the two thyristors leads in full conduction, if α lies between 90° and 180° the thyristors lead partially, and if $\alpha = 180^\circ$ the thyristors does not lead.[5]

The TSC is composed of a capacitor placed in series with two thyristors assembled in antiparallel. [1]

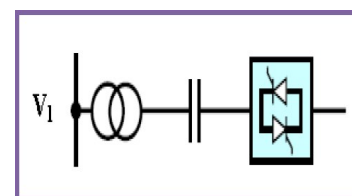

Figure 2. Structure of TSC.

The two thyristors has role to switch on and switch off the condenser. [7]

The association of these two devices gives us the SVC compensator of "TSC-TCR" type which comprises (n) benches of "TSC" and a simple "TCR" which are connected in parallel.

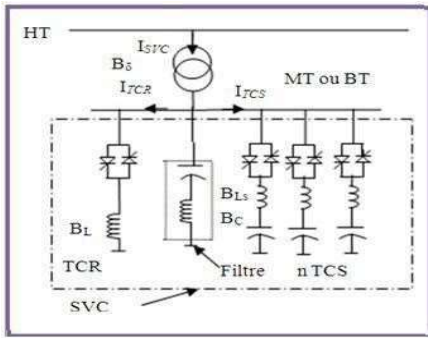

Figure 3. General case of n benches of TSC & 1TCR.

The condensers can be connected in discrete stages. The general principle of SVC (TSC-TCR type) is that the TSC provided of the reactive power in a complete way of only one bench, two or three benches according to the need, and the TCR absorbs a percentage to obtain the quantity of the reactive power desired.

III. MODELING & CONTROL OF SVC

A. Modeling of SVC

The equivalent diagram of SVC is represented by the (Bsvc) susceptance connected in parallel with the network in the connection point, Fig. 4:

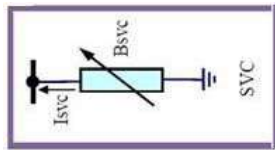

Figure 4. Equivalent diagram of SVC.

If SVC supposed ideal, does not contain a resistive component ($G_{svc} = 0$), therefore it does not consume active energy of the power grid:

$$P_i = 0 \tag{1}$$

Its reactive power is function of the voltage to the connection bus and of Bsvc susceptance:

$$Q_i = -|V_i|^2 B_{SVC} \tag{2}$$

If Q_{svc} is absorbed by SVC $\Rightarrow Q_{svc} > 0 \Rightarrow$ inductive behavior.
 If Q_{svc} is provided by SVC $\Rightarrow Q_{svc} < 0 \Rightarrow$ capacitive behavior.

For our study we take $n=3$, i.e (3TSC+1TCR), Fig. 5, presents the simplified diagram of this model:

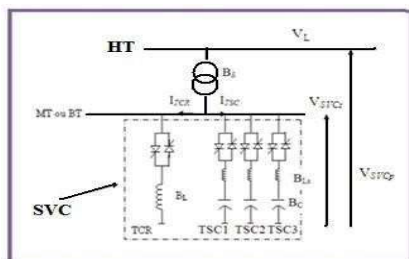

Figure 5. SVC of (3TSC+1TCR) type.

The maximum and the minimum susceptance of this model are:

$$B_{SVC_{max}} = \frac{B_B + B_{3C}}{B_B + B_{3C}} \tag{3}$$

$$B_{SVC_{min}} = \frac{B_B(B_{3C} + B_{TCR})}{B_B + B_{3C} + B_{TCR}} \tag{4}$$

With:

$$B_{3C} = 3 * B_C \tag{5}$$

$$B_C = \frac{B_C B_{LC}}{B_C + B_{LC}} \tag{6}$$

The total current of the compensator is:

$$I_{SVC} = V_m \frac{B_B(B_{3C} + B_{TCR})}{B_B + B_{3C} + B_{TCR}} \tag{7}$$

The currents of the three capacitive modes can be given by the following equation:

$$I_{3C} = -V \frac{B_B B_{3C}}{B_B + B_{3C}} \tag{8}$$

And for the inductive mode:

$$I_{SVC} = V \frac{B_B B_L}{B_B + B_L} \tag{9}$$

Fig. 6 watches the principal constitution of one TSC only:

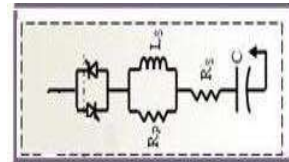

Figure 6. Principal constitution of one TSC only.

The real characteristics of the TSC used are the following ones:

$$L_p = 1.03 \cdot 10^{-2} H; R_p = 4.26 \cdot 10^{-2} \Omega; R_s = 95.85 \mu\Omega = 9.58 \cdot 10^{-5} \Omega$$

According to Fig. 6, the impedance of only one phase of TSC is:

$$Z_{TSC} = \frac{1}{\frac{1}{R_p} + \frac{1}{jL_p\omega}} + R_s + \frac{1}{jC\omega} \tag{10}$$

$$Z_{TSC} = R_s + \frac{R_p(L_p\omega)^2}{R_p^2 + (L_p\omega)^2} + j \left(\frac{R_p^2 + R_p(L_p\omega)^2}{R_p^2 + (L_p\omega)^2} - \frac{1}{C\omega} \right) \tag{11}$$

Then we obtain:

$$Z_{TSC} = 0.0095 - j8.18 \Omega = |Z_{TSC}| = 8.18 \Omega$$

Fig. 7, watches the principal constitution of TCR:

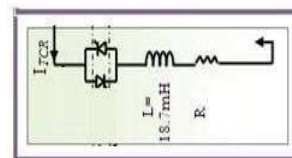

Figure 7. Principal constitution of TCR.

The real characteristics of the TCR used are the following ones:

$$L = 18.7 \cdot 10^{-3} H; R_s = 0.141 \Omega$$

According to the Fig. 7, the impedance of only one phase of TCR is:

$$Z = R + jL\omega = |z_{TCR}| = 7.05\Omega \quad (12)$$

B. Control of SVC

The control of (3TSC+1TCR) type is summarized in the synoptic diagram presented in Fig.8:

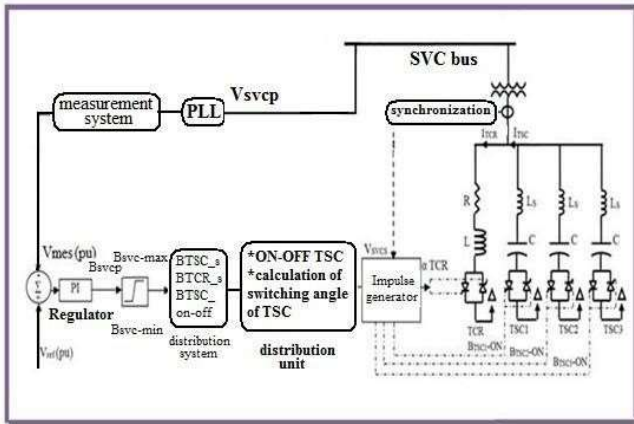

Figure 8. Command circuit diagram of SVC (3TSC+1TCR).

The control system of SVC comprises the following four principal modules:

1) *Measurement System*: This system measures the fundamental of primary voltage of the transformer; the calculation of fundamental is completed by the discrete Fourier method during one cycle of operating.

2) *PI regulator of voltage*: Ensures a voltage regulation around the set point “Vref”. PI regulator provides the suitable value “Bsvc” for each point of operating. [6] The SVC current is given by equation:

$$I_{SVC} = B_{SVC} V_{SVC} \quad (13)$$

Fig. 9 watches the regulation loop of voltage at the SVC bus:

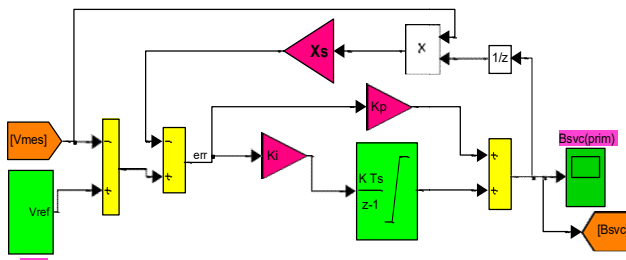

Figure 9. PI regulator loop of voltage.

The system can be having a time-constant in open loop given by:

$$T_D = \frac{1}{X_S + K_p} \quad (14)$$

The time-constant in closed loop is given by:

$$T_F \cong \frac{X_S}{(X_L + X_S)} * T_D \quad (15)$$

The state equation of PI control is given by:

$$F(Z) = K_p + K_i \frac{Z}{z-1} \quad (16)$$

3) *Distribution unit*: This unit uses the value "Bsvc" provided by the regulator to calculate the switching angle of the TCR and the (ON/OFF) state of the three benches of "TSC". The calculation of each suitable switching angle for each value of BSCR is carried out via a database (look up table) generated from the basis of equation:

$$B_{TCR} = \frac{2(\alpha - \alpha_0) + \sin(2\alpha)}{\pi} \quad (17)$$

4) *Impulses generator*: The impulse generator uses the switching angle "α" and the (ON/OFF) state of the three benches of "TSC" to generate the impulsions. It is also connected with the synchronization unit used to measure the phase of the secondary voltage of the transformer.

IV. SIMULATION RESULTS

The real test network (T-line, 400KV) of renewable energy system (Biomass .P.S) of our study is simulated in MATLAB/SIMULINK interface, is shown in Fig.10. The parameters of the system are listed in tables 1 and 2.

The SVC model is located at the sending end of the transmission line which feeds a variable load in time in the bus reception, and follows the changes in reference values of the line active and reactive powers caused by this load (table 3).

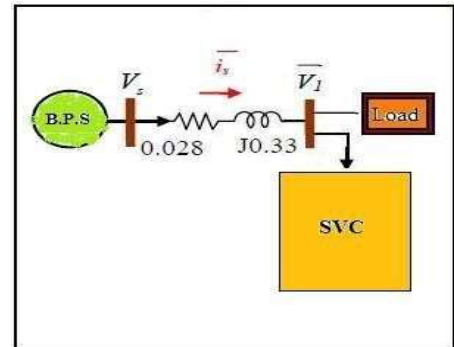

Figure 10. UPFC installed in the real test network (in per units).

TABLE 1. POWER SYSTEM PARAMETERS (BIOMASS .P.S)

Line length(Km)	MVA	V(KV)	R+JLw (pu)	f (Hz)
200	1000	400	0,028+j0,33	50

TABLE 2. PARAMETERS OF SVC

Rsvc (pu)	Lsvc (pu)	C of TSC (pu)	L of TCR (pu)	V (KV)
0,025	0,625	0,0094 * 3	-0,109	20

TABLE 3. REFERENCES OF ACTIVE & REACTIVE POWERS

Time (sc)	0 0,6	0,6 1	1 1,4	1,4 1,8	1,8 2,2
P (pu)	1	1,3	1,4	1,4	1,1
Q (pu)	0,32	0,12	0,42	0,43	0,14

The traces of some characteristic values of SVC are represented in the following figures:

A. Results Without SVC

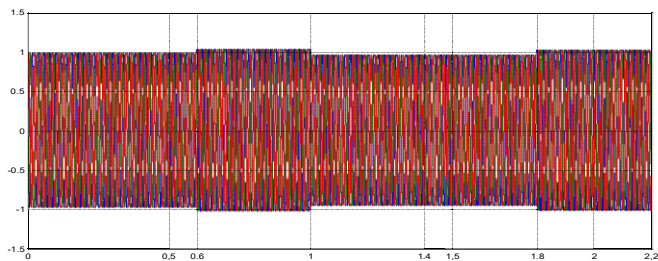

Figure 11. Voltage at reception bus not compensated.

Fig. 11, watch different variations caused on voltage at reception bus, whose interval [0-0.6sc] we have a small voltage drop caused by inductive load ($P_{0sc}=1pu$, $Q_{0sc}=0.32pu$), then we have a rise in voltage because of load ($P_{0.6sc}=1.3pu$, $Q_{0.6sc}=0.12pu$). At time ($t=1sc$) we notice an appreciable voltage drop due to the load ($P_{1sc}=1.4pu$, $Q_{1sc}=0.42pu$), however a very small variation in the reactive power ($P_{1.4sc}=1.4pu$, $Q_{1.4sc}=0.43pu$) causes a very small increase in voltage. In the last interval [1.8-2.2sc], it appears another rise in voltage due to the change of references powers to ($P_{1.8sc}=1.1pu$, $Q_{1.8sc}=0.14pu$).

B. Results With SVC

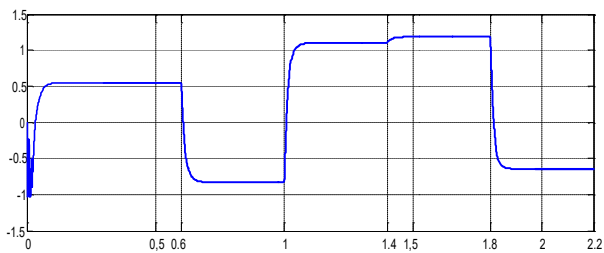

Figure 12. Variation of primary susceptance (Bsvc).

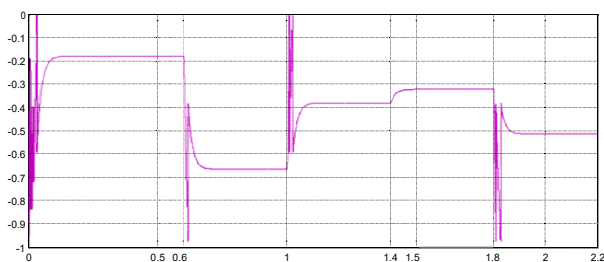

Figure 13. Effective susceptance of TCR (BTCCR).

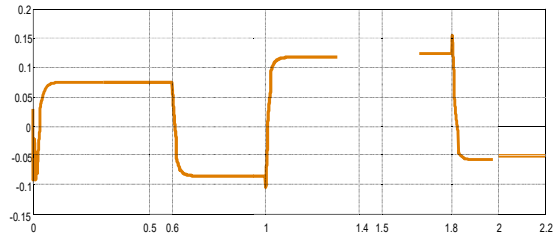

Figure 14. Reactive power (Qsvc) injected or absorbed by SVC.

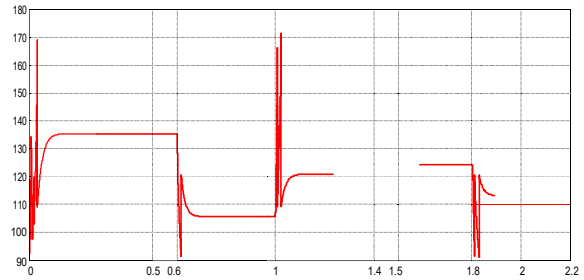

Figure 15. Switching angle (α) of TCR.

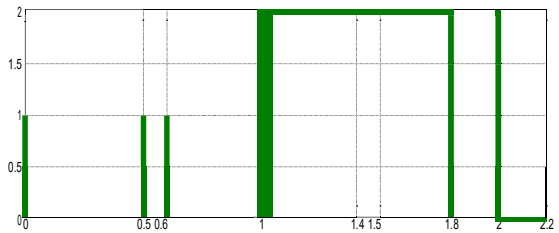

Figure 16. Number of bench (n) of TSC used.

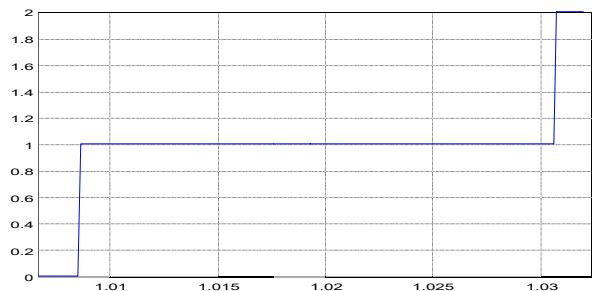

Figure 17. SVC response time (Zoom of Fig. 32, at the interval [1 1, 03 sc]).

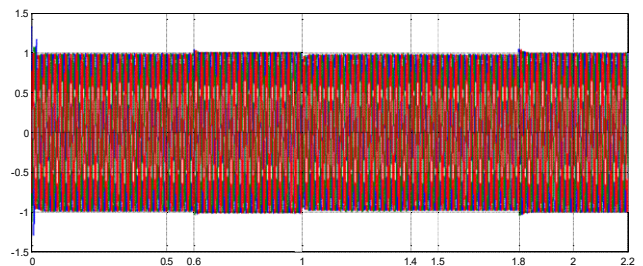

Figure 18. The reception voltage compensated (Vr).

1) *Primary susceptance (B_{svc}):* generally the curve of primary susceptance of SVC (B_{svc}) has the same fundamental form as that is obtained from the reactive power Q_{svc}. When SVC injects the reactive power B_{svc} takes positive values (intervals: [0 0.6sc], [1 1.4sc], [1.4 1.8sc]), and when SVC absorbs the reactive, B_{svc} takes negative values (intervals: [0.6 1sc], [1.8 2.2sc]), Fig.12.

2) *Active & reactive powers of SVC (P_{svc}, Q_{svc}):* Into the intervals [0-0.6sc], [1-1.4sc] SVC injects an amount of reactive power Q_{svc} about (0.074 pu), (0.11 pu) successively for raising the V_r voltage. And at the moment (t=1.4sc) a very small waning in voltage compared to the interval [1-1.4sc] causes a very small rise in reactive power injected by SVC, which shows the great sensitivity of our device to the small variations in the power grid. In the intervals [0.6-1sc], [1.8-2.2sc] the load causes a rise in voltage to the reception bus V_r and makes that the SVC absorbs reactive energy about (0,083 pu), (0.055 pu) successively from the network to compensate V_r voltage (Fig. 14). This behavior of SVC owing to the fact that once inject and other absorb shows the flexibility of our device. The exchange of active power between the network and SVC is generally null (P_{svc}=0).

3) *Effective susceptance of TCR (B_{TCR}):* The analytical calculation of B_{TCR} according to α with use of equation (17) gives us the following table:

TABLE 3. REFERENCES OF ACTIVE & REACTIVE POWERS

Time (sc)	0 0,6	0,6 1	1 1,4	1,4 1,8	1,8 2,2
α (°)	135,3	105,6	120,75	124,38	113,2
B _{TCR} (pu)	-0,179	-0,662	-0,378	-0,321	-0,511

The database (look up table) of distribution unit can give numerically the same values computed analytically in the table. We deduce: the distribution unit used in the SVC functions scrupulously. Fig. 13.

4) *Switching angle (α) of TCR:* According to the Fig. 15, into the interval [0 0,6sc] only one bench of TSC injects reactive power whereas the TCR absorbs only very little of reactive to obtain the desired Q_{svc} value, which explains the switching angle about (135, 3°). In the interval [1 1,8sc] we have two benches of TSC in service and the TCR absorbs the excessive quantity with a switching angles of (120,75°) for the interval [1 1,4sc] & (124,38°) for [1,4 1,8sc]. When the TCR functions only, (α) takes important values (a little close to 90°), about (105, 6°) in the interval [0, 6 1sc] and (113, 2°) in the interval [1, 8 2,2sc].

5) *Number of benches (n) of TSC:* When SVC injects a minor amount of reactive power (interval [0 0.6sc]), it is noted that only one bench of TSC is in service. When the compensator provides more of reactive with appreciable values (interval [1 1,8sc]), the SVC uses two (02) benches of TSC. In addition when SVC absorbs the reactive power Q_{svc} of the network (intervals [0.6 1sc] and [1.8 2,2sc]), the TSC is completely out of service, and only the TCR which functions (Fig. 16).

6) *Response time of SVC (τ):* According to the Fig. 17, SVC has a response time about ($\tau=0,023sc$), to compensate the reactive power and to regulate the voltage of power grid as quickly as possible, which gives another characteristic of SVC, it is the operating speed.

V. CONCLUSION

This paper presents the modeling and control of SVC connected in a real test network, and to test the operating of this device, we used certain values of active and reactive references powers, the results obtained of simulation in SIMULINK/MATLAB interface watch that the reactive power is optimized and the voltage of the bus where SVC is connected is regulated. We validated the good performance and good characteristics of SVC such as: the great sensitivity to the small variations in the power grid, the flexibility and speed of operating, that which enables us to say that the SVC built an intelligent grid of renewable energy system.

REFERENCES

- [1] P. Kundur, "Power system stability and control", McGraw-Hill, New York. 1999.
- [2] E.GH.Sahraki, R, "Apport de l'UPFC à l'amélioration de la stabilité transitoire des réseaux électriques", Thesis of doctorate, Henri Poincaré University, Nancy- I, October 13rd, 2003.
- [3] N. G. Hingorani, L. Gyugyi, "Understanding FACTS", Piscataway, NJ 08855-1331.
- [4] Vijay K. Sood "HVDC and FACTS controllers, applications of static converters in power systems", New York. 2004. EBook ISBN: 1-4020-7891-9.
- [5] C. Jacques, G. de Preville, J-Louis Sanhet, "Fluctuations of voltage and flicker - Evaluation and attenuation (part I and II)", engineer Techniques (D4.315).
- [6] P. Kundur, "Power system stability and control", McGraw-Hill. New York. 1999.
- [7] De Vre R, Jacquet B, "Disturbances in electrical and electronical installations, problems and solutions", Information note.
- [8] H. Sekhane, D. Labed, "Adjustment of voltage & the controle of reactive power in an HT network by STATCOM device", 2nd international conference on electronics electrical and automatic, Oran, Algeria, November 26-27 2013.