

Maximum Power Point Tracking For Photovoltaic Systems: A Comparison Between GAs and PSO Approaches

M. Bechouat^{#*1}, Y. Soufi^{*2}, S. Kahla^{#3}, B. Guendouz^{*4}, M. Sedraoui^{#5}

[#] Department of Electronic and Telecommunication,
Faculty of Sciences and Technology, University of 8 May 1945 of Guelma,
BP 40, Guelma 24000, Algeria.

^{*}Unité de Recherche Appliquée en Energies Renouvelables, URAER, Centre de Développement des Energies
Renouvelables, CDER, 47133, Ghardaïa, Algérie

Labget laboratory, Department of Electrical Engineering, University of Tébessa, Algeria

¹mohcene.oui@gmail.com

²y_soufi@yahoo.fr

³samikahla40@yahoo.com

⁴guendouze_b@yahoo.fr

⁵msedraoui@gmail.com

Abstract— Particle Swarm Optimization (PSO) and Genetic Algorithms (GAs) are proposed in this paper to generate a duty cycle. The duty cycle (D) used in Pulse Width modulation (PWM) to reproduced control switch for the boost converter by the maximum power point tracking (MPPT) for a photovoltaic (PV) system. As results indicated, using particle swarm optimization (PSO) and Genetic Algorithms (GAs) are used for stabilization of a photovoltaic system (PV).

Keywords—Photovoltaic systems, Boost, PWM, MPPT, PSO, GAs

I. INTRODUCTION

Mathematical modeling of a PV module depend equations related with the temperature and insolation. the validation of model very important after modeling for the there must be a very close model of reality so whatever the result this model is a approximated model, we named model represents when compared with real results. PV system cannot be modeled as a constant DC current source because its output power is varied depending on the load current, temperature and insolation.

In this paper use real values for the temperature and insolation, These values are taken for Unit for Applied Renewable Energy- Ghardaïa -Algeria- "URAER" And so on 11.05.2012 during each hour, where the insolation measured by K&Z CHP1 pyrliometer and the temperature measured by Campbell CS215.

Generally, MPPT is adopted to track the maximum power point in the PV system. The efficiency of MPPT depends on both the MPPT control algorithm and the MPPT circuit. The MPPT control algorithm is usually applied in the DC-DC converter, which is normally used as the MPPT circuit

Our contribution in this paper is created an optimization method capable of choosing optimal duty cycle depending on the system performance.

The particle swarm optimization (PSO) is a technique that evolutionary uses a "swarm" of solutions candidate to develop an optimal solution of the problem. The degree of optimality is measured by a fitness function defined by user [1]. The PSO is different from other methods of evolutionary computation in order that members of the swarm called " particles " are scattered in space of the problem [1].

The Genetic Algorithms (GAs) is a technique based on natural selection, the process that drives biological evolution. The GAs uses a "population" of solutions candidate to develop an optimal solution of the problem. The degree of optimality is measured by a fitness function like PSO. The GAs is different from other methods of evolutionary computation in order that members of the public called " individual " are scattered in space of the problem and create the next generation from the current population [2].

II. PHOTOVOLTAIC EQUIVALENT CIRCUIT MODEL

A photovoltaic model presented by general mathematical model equations using the output and the input, there is a current source contains the illumination value depends [3] in parallel with a diode and in parallel with a resistor in series with a further resistor, the numbers of the resistors in parallel or in series gives the position of the cell is in series or in parallel [4], that is to say the objective that we are interested in current or voltage. The typical equivalent circuit of PV cell is shown in Fig. 1 [3].

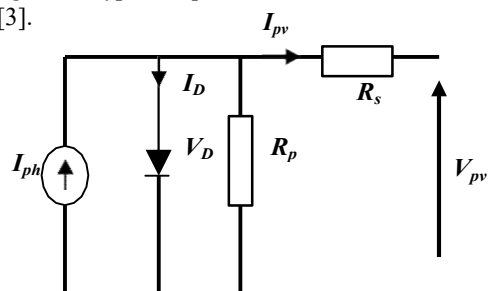

The basic equations describing the I-V characteristic of the PV cell solar model are given in the following equations [5]:

$$0 = I_{ph} - I_D - I_{pv} - \frac{V_{pv} + I_{pv} R_p}{R_p} \tag{1}$$

$$I_D = I_0 \left(e^{V_D / V_T} - 1 \right) \tag{2}$$

Where:

$$V_D = V_{pv} + I_{pv} \cdot R_s \tag{3}$$

$$V_T = \frac{n \cdot K \cdot T}{q} \tag{4}$$

And:

I_{pv} : The cell current (A)

I_{ph} : The light generated current(A)

I_D : The Shockley diode equation (A).

I_0 : The diode saturation current (A).

R_s : The cell series resistance (Ohms).

R_p : The cell shunt resistance (Ohms).

V_D : The diode voltage (V).

V_T : The temperature voltage (V).

V_{pv} : The cell voltage (V).

n : Dimensionless junction material factor

K : The Boltzmann constant $1.38 \cdot 10^{-23} J/K$

T : The temperature measured by Celsius

q : The electron charge $1.602 \cdot 10^{-19} C$

R_p eliminate in the new model.

Simplified mathematical model given by Shaowu Li in [4], but he illuminates the second parts "AP":

$$I_{pv} = I_{sc} - c \cdot e^{\frac{V_{pv} - \Delta V}{c_2 \cdot V_{oc}}} - 1 + \Delta I \tag{5}$$

Where:

$$c = 1 - \frac{I_m}{I_{sc}} e^{-\frac{V_{oc}}{c_2 \cdot V_{oc}}} \tag{6}$$

$$c_2 = \frac{V_m}{V_{oc}} - 1 / \ln \left(1 - \frac{I_m}{I_{sc}} \right) \tag{7}$$

$$\Delta I = I_{ph} - I_{sc} \tag{8}$$

$$I_{ph} = \frac{E}{E_n} [I_{sc} + K_I * \Delta T] \tag{9}$$

$$\Delta V = R_s * \Delta I - K_v * \Delta T \tag{10}$$

$$\Delta T = T - T_n \tag{11}$$

K_I and K_v are the cell's short-circuit current temperature coefficient, E and E_n are the insolation and the nominal insolation, I_{sc} , V_{oc} , V_m and I_m represent short circuit current, the open circuit voltage, the maximum power point current and voltage at nominal conditions (E_n , T_n)= (1000, 25°C), respectively.

III. SIMULATIN AND VALIDATION MODEL

A photovoltaic mathematical model usually presented by the model equations and inputs sortie, it contains a current source depends on the insolation value [6] in parallel with a diode and in parallel with a resistor in series with a resistance, the numbers of resistors in series or in parallel gives the position of the cell either in series or in parallel [6] that is to say the objective that we are interested in current or voltage.

Model validation usually seen after the simulation, so in our PV model validated after the simulation *Matlab / Simulink*.

Fig.2 shows the structure of validation model.

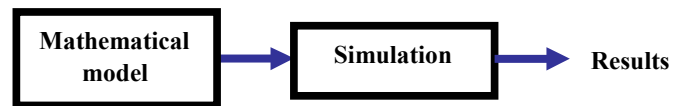

Fig.2 Structure validation model.

Fig.3 shows the PV module type **S235P60**.

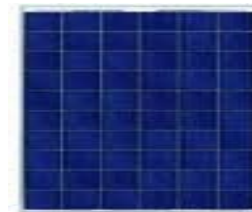

Fig.3 PV module type S235P60.

The following table contains some of the parameter values were used in the simulation for **S235P60** type.

TABLE I

THE SPECIFICATION OF PV SYSTEM MODULE USED IN THE SIMULATION

CELL TYPE	POLYCRYSTALLINE CELL 10*6
MAXIMUM POWER P_{MAX} [W]	235.05
RANGE OF RATED POWER P [W]	-0/+4.99
VOLTAGE, MAX POWER [V]	28.70
CURRENT, MAX POWER [A]	8.19

OPEN CIRCUIT VOLTAGE $V_{oc}[V]$	36.5
SHORT CIRCUIT CURRENT $I_{sc}[A]$	8.59
NOMINAL TEMPERATURE $T[^\circ C]$	25.000
NOMINAL INSOLATION $E[W/M^2]$	1000.0
SERIES RESISTANCE $[\Omega]$	2.2000
SHUNT RESISTANCE $[\Omega]$	CARELESS
TEMPERATURE CO-EFFICIENT OF SHORT CIRCUIT CURRENT AND VOLTAGE $[A/^\circ C]$	0.030

Fig.4 shows the simulation of PV module on the tool *matlab/simulink* for temperature or insolation varied.

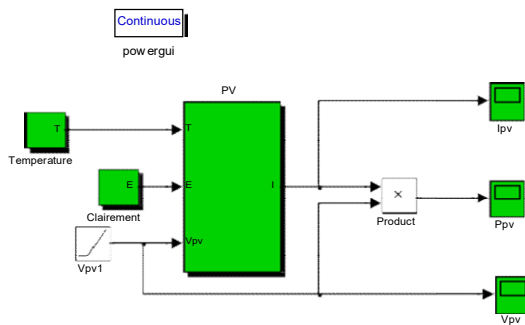
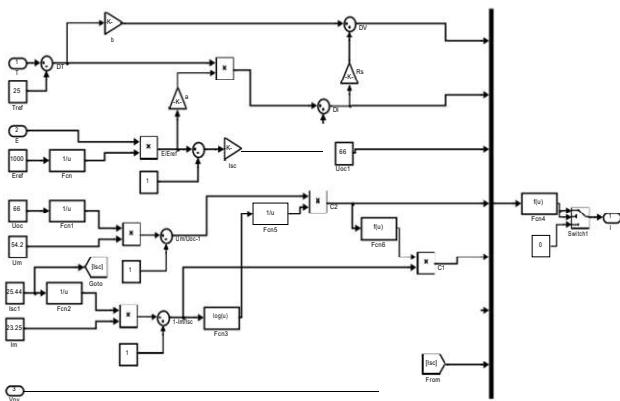

Fig.4 PV module model by insolation or temperature variable.

Fig.5 shows the PV module subsystem.



Experience shows that the open circuit voltage of PV solar cell decreases with increasing temperature in the cell indicated [6], as the peak power decreases as the temperature increases. Once we set the heat and change the insolation of a small to large values process. Another time the reverse operation is set to say the insolation and temperature change.

Simulation results prove that our model closely representative of reality and this is what allows us to apply all methods of control. Results also allow validation of the model.

Fig.6 shows Current-Voltage and Power-Voltage characteristics of PV model for constant insolation.

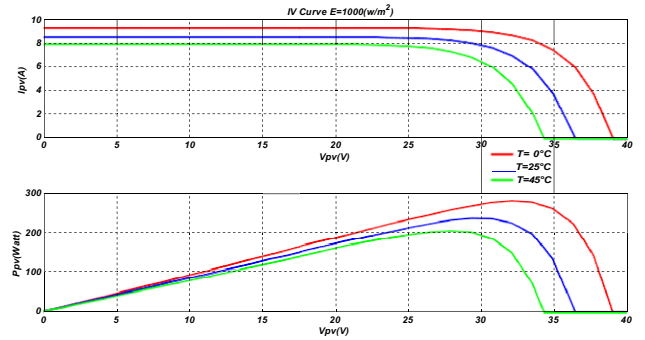

Fig.6 Influence of the temperature of junction for constant insolation.

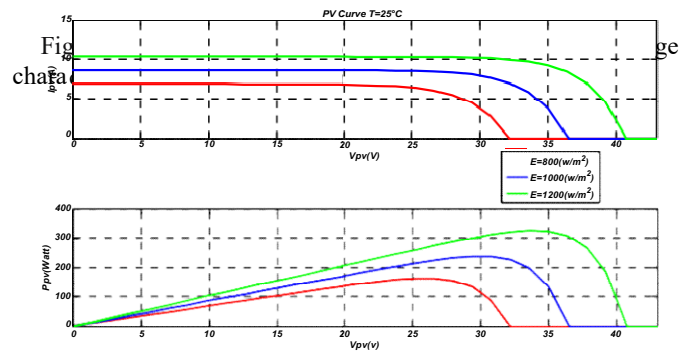
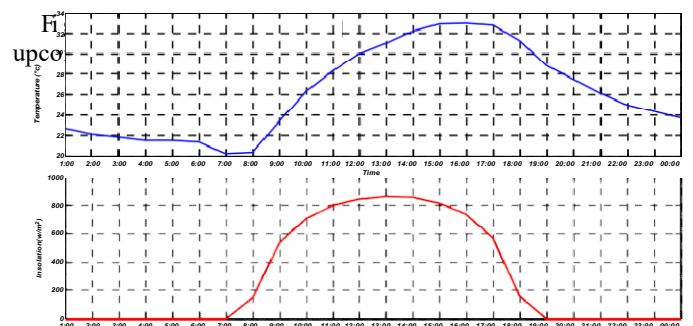

Fig.7. Influence of the solar radiation for constant temperature.

IV. Temperature and insolation

The data, which will use it in their own programming temperature and insolation, are real taken from Unit for Applied Renewable Energy- Ghardaïa-Algeria-“URAER” during each hour in the month of May where the sunrise begins at about seven o'clock in the morning and ends at seven in the evening that any insolation would be non-existent at this time. While the temperature will change randomly.



V. MECHANISM OF GENETIC ALGORITHMS AND OF PARTICLE SWARM OPTIMIZATION

A) PARTICLE SWARM OPTIMIZATION

The Particle swarm optimization (PSO) is first introduced by Kennedy and Eberhart in 1995 [1]. It can be obtained high quality solutions within shorter calculation time and stable convergence characteristics with PSO algorithm than other stochastic methods such as genetic algorithm.

Particle swarm optimization uses particles which represent potential solutions of the problem. Each particles fly in search space at a certain velocity which can be adjusted in light of proceeding flight experiences. The projected position of i^{th} particle of the swarm x_i , and the velocity of this particle v_i at $(t+1)^{th}$ iteration are defined as the following two equations in this study [1]:

$$\begin{aligned} v_{iD}^{t+1} &= k \cdot v_{iD}^t + c_1 r_1 (P_{iD}^t - x_{iD}^t) + c_2 r_2 (g_{iD}^t - x_{iD}^t) \\ x_{iD}^{t+1} &= p_{iD}^t + v_{iD}^{t+1} \end{aligned} \quad (12)$$

where, $i = 1, \dots, n$ and n is the size of the swarm, D is dimension of the problem space, k is the momentum or inertia, c_1 and c_2 are positive constants, r_1 and r_2 are random numbers which are uniformly distributed in $[0, 1]$, t determines the iteration number, p_i represents the best previous position (the position giving the best fitness value) of the i^{th} particle, and g represents the best particle among all the particles in the swarm. The algorithm of PSO can be depicted as follows [1]:

1. Initialize a population of particles with random positions and velocities on D -dimensions in the problem space,
2. Evaluate desired optimization fitness function in D variables for each particle,
3. Compare particle's fitness evaluation with its best previous position. If current value is better, then set best previous position equal to

the current value, and p_i equals to the current location x_i in D -dimensional space,

4. Identify the particle in the neighborhood with the best fitness so far, and assign its index to the variable g ,
5. Change velocity and position of the particle according to Equation (12).
6. Loop to step 2 until a criterion is met or end of iterations.

At the end of the iterations, the best position of the swarm will be the solution of the problem. It is not possible to get an optimum result of the problem always, but the obtained solution will be an optimal one. It can not be able to an optimum result of the problem, but certainly it will be an optimal one.

B) GENETIC ALGORITHMS

Genetic algorithms are inspired of biological, exploiting exactly the idea of reproduction (Darwin) so that the genes passed down from generation to generation. The principle proposed by "J. Holland 1975", the GAs has been successfully used to manage the wide variety of problems, such as monitoring, research, etc.

The GAs is inspired by the mechanism of natural selection where strongest individuals are likely to be the winners in a competitive environment. The GAs uses a direct analogy natural evolution. With the method of genetic evolution, optimal solution can be found and represented by the overall winner of the genetic game.

the genetic algorithms based on four steps, it started with a random creation of a population is called as initial population is the first generation after this a very important step is the

evaluation by the fitness function, so the creation or generation of new population through reproduction (selection) this step of minimizing or maximizing, then crossover and mutation. A simple template for the operation of a genetic algorithm is shown in the pseudo code [2], see MATLAB help for understood the steps selection, crossover and mutation.

```

Choose an initial population of chromosomes;
While termination condition not satisfied do
  Repeat
    If crossover condition satisfied then
      - Select parent chromosomes;
      - choose crossover parameters;
      - perform crossover
    If mutation condition satisfied then
      - choose mutation points;
      - perform mutation;
      - evaluate fitness offspring
  Until sufficient offspring created;
  Select new population
End while
  
```

VI. PSO OR GAs LEARNING ALGORITHMS

To accelerate the convergence of PSO and GAs, it was proposed to find a better solution in a minimum computation time and accuracy, we calculate the best solution, on minimizing a certain criterion (objective function) is the mean square error (MSE) calculated by the following equation:

$$MSE = \frac{1}{nT} \sum_{i=1}^n e(K)^2 \tag{13}$$

Where: n is the total number of samples and T the sampling time, $e(k)$ is the difference between the value of the power out and the value of the power PV, so the goal is to extract the maximum power.

The block diagram (see Fig.9) shows the strategy optimization of the duty cycle:

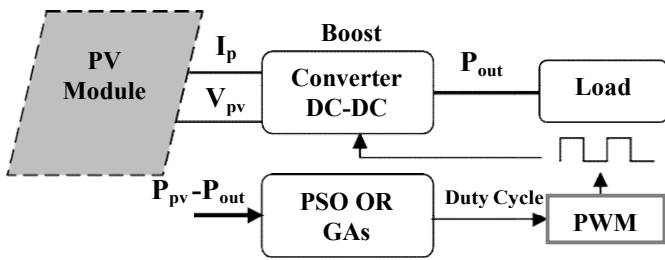

Fig.9 Typical diagram of MPPT using PSO or GAs in a PV .System.

The pseudo code that describes the procedure is the following:

```

Initialization (creation of the initial swarm or population)
For i=1 to number of swarm or population ‘iteration’
    For j=1 to number of particles or of individuals
        Create the member ship function for the particle j or of individual j
        Run the simulation of the PV
        Evaluate fitness
    End j
    Rank the particles or individuals on their fitness function
    For PSO: Update new swarm or by comparison the position of the particles
    For GAs: create new generation by steps selection, crossover and mutation.
End i
    
```

For the GAs and PSO programmed using MATLAB toolbox.

VII. RESULTS SIMULATION

The proposed GAs or PSO has been modelled and simulated using MATLAB/Simulink.

Fig.10 shows the simulation of applicant PSO or GAs control for PV module for temperature and insolation varied.

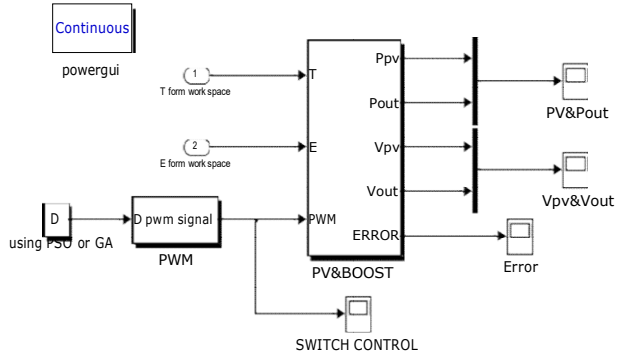

Fig.10 PV module using PSO or GAs control by insolation and temperature variable.

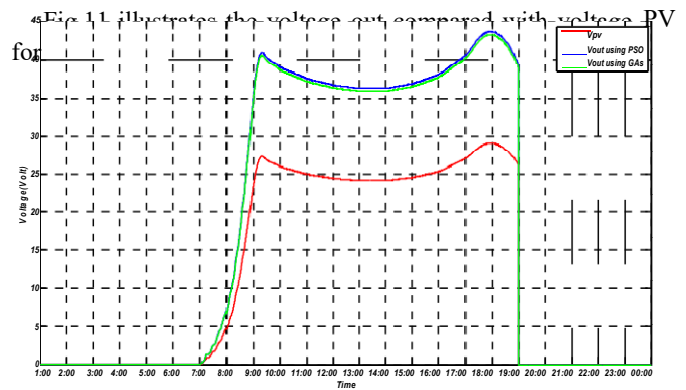

Fig.11 Voltage PV and Voltage Out For different control.

From this figure, the DC-DC converter and controls properly perform their roles. The converter provides the optimum conditions in a voltage at the top to that provided by the PV module output, it observed that the PSO better then GAs.

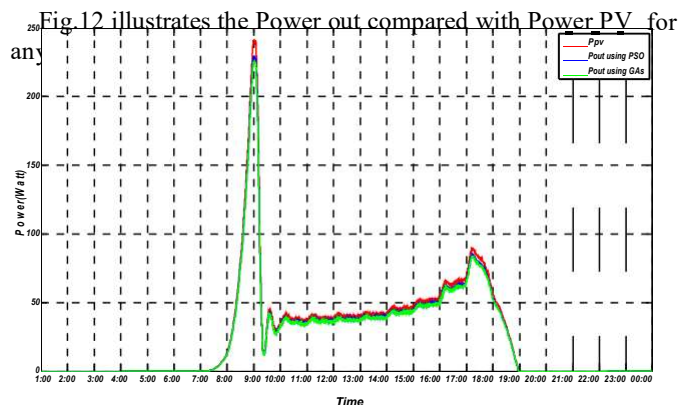

Fig.12 Voltage PV and Power Out For different control.

Sudden change in energy or voltage for the PV resulting from the sudden change of temperature and insolation but for the out is the result of the values used in the boost Inductance, Resistor and Capacitor. We can use filter to reduce this sudden change because it could disrupt the charge.

Note that there is a reduction in energy by 5% use PSO, 5.25% when use GAs.

VIII. CONCLUSION

From the results obtained, we can observe that using both methods give good results of optimizations that is to say maximize power (objective MPPT). But the PSO is better than GAs. Also it is very fast in executing the simulation.

In the future different optimization method is applied on a solar panel not a module.

REFERENCES

- [1] J. Kennedy and R. Eberhart, 1995. "Particle swarm optimization", in *Proc.IEEE Int. Conf. Neural Networks (ICNN'95)*, vol. IV, Perth, Australia, p p. 1942–1948.
- [2] G. Renner, A. Ekart "Genetic algorithms in computer aided design", computer aided design, Vol.35, No.8, pp.709-726, 2003.
- [3] P. Takun, S. Kaitwanidvilai and C. Jettanasen, "Maximum Power Point Tracking using Fuzzy Logic Control for Photovoltaic Systems" *Proceeding of the International MultiConference of Engineers IMECS 2011, March 16-18,2011, Hong Kong.*
- [4] S.Panwar, R.P. Saini "Development and Simulation of Solar Photovoltaic model using Matlab/simulink and itsparameter extraction", *International Conference on Computing and Control Engineering (ICCCE 2012)*, 12 & 13 April, 2012.
- [5] Li.S, 2014."A MPPT control strategy with variable weather parameterand no DC/DC converter for photovoltaic systems" *Solar Energy*, vol 108, 117-125. doi: 10.1016/j.solener.2014.07.002.
- [6] Basil M. Hamed Mohammed S. El-Moghany, "Fuzzy Controller Design Using FPGA for Photovoltaic Maximum Power Point Tracking" *International Journal of Advanced Research in Artificial Intelligence*, Vol. 1, No. 3, 2012.