

# Comparative studies between Lithium-Ion , Nickel Cadmium and Nickel Metal hydride Batteries for wireless sensor Networks

Boubakeur Hamlili\*, Khelifa Benahmed\*\*, Brahim Gasbaoui\*

\* Department of electrical engineering, faculty of technology tahri mohamed University, Bechar - 08000 Algeria.

\*\* Department of mathematics and computer science, faculty of exact sciences tahri mohamed University, Bechar - 08000 Algeria.

boubakeur.adel@yahoo.fr, benahmed\_khelifa@yahoo.fr, gasbaoui\_2009@yahoo.com

**Abstract** – Energy in Wireless Sensor Networks (WSNs) is of paramount importance for the remotely deployed energy stringent sensor nodes. These nodes are typically powered different batteries technologies via an efficiency bidirectional DC-DC (BDC) converter. In this purposed, this article deals with comparative studies between three different technologies Lithium-Ion, Nickel-Metal hydride and nickel-Cadmium, their capacity depends on the state of charge (SOC) of the battery. Energy is considered as a scarce resource for a sensor node, specifically when a node is deployed in a remote region and once it depletes the available energy, it is almost impossible to provide supplant energy. The purpose of energy conservation in wireless sensor networks is primarily to increase the lifetime of a sensor node and subsequently the entire network, which ensures availability of the various services provided by each node. The result obtained is satisfactory for our (WSNs) simulated in a MATLAB / SIMULINK environment. Moreover, the obtained results prove the robustness of the proposed control law against variations in load resistance in the studied converter .The most cost effective battery and subsequently better manage the power consumption in a wireless sensor network. The proposed control law increases the utility of (WSNs) autonomous under several power variations.

**Keywords**– Wireless Sensor Networks, SOC, Power management, SOC bidirectional DC-DC converters.

## I. INTRODUCTION

In recent years, technical advances in terms of performance and miniaturization in electromechanical Microsystems (MEMS) and the technological advancement of information and communication have led to the development of a communicating micro component called sensor, and their deployment in several monitoring applications (Environmental, habitat, industrial, agriculture, intelligent transport, military, medical, domestic automation etc.) allow the use of a new strategy. Wireless Sensor Networks (WSNs),

which represent cost-effective solutions for remote monitoring and data processing in complex and distributed environments [1].

Wireless sensor networks are made up of several sensors (nodes) and can communicate with each other wirelessly and which are generally powered by a battery of very limited and almost never renewable energy, the objective of optimizing Energy consumption in wireless sensor networks aims primarily at increasing the lifetime of a sensor node and the long-term operation of the network, which ensures the availability of the various services provided by these networks [2].

A node often keeps a set of low-maintenance maintenance-free devices such as microcontroller, memories, one or more sensors, battery and a radio module for communication, the goal is to increase the lifespan of these small appliances , It is a problem of energy management (the stack), in the literature the researchers have made a lot of efforts to find methods trying to optimize the energy consumption at the level of the sensor and the good quality of service of the network, based either on the manufacture of the hardware (circuits and / or the battery of physical matter), or used the approach of the rechargeable batteries, or used techniques (algorithms) touching protocol layers for example The MAC layer and / or the NETWORK layer [3].

In this article we are interested in the first strategy, that is to say exactly the choice of type of battery suitable for the nodes in an WSN, therefore it is necessary that the only source of energy provided by the stack Must be replaced or collaborated by another energy source by proposing a comparative technique to contribute to the improvement of performance and optimization of energy conservation in the network in order to extend the energy This study consists in using the control of a Buck Boost DC-DC converter for three types of battery during three phase of service of (WSNs), evaluating the performance of the proposed stack, a test

of Simulation is carried out during the service phases of the node.

The remained of this paper is organized as follows. In section 2, the design of wireless sensor network. Section 3 shows the basic operation of a lithium-Ion battery. Section 4 describes the bidirectional DC-DC converter. Section 5 five some simulation results and discussion carried in MATLAB/. Finally, the conclusion is drawn in section 6.

## II. BASIC CONCEPTS OF A WIRELESS SENSOR NETWORK AND DISSIPATION OF ENERGY IN SENSOR NODES

The technological advances in information and communications have given rise to a new generation of computer network adapted to a wide range of application very varied are the networks of sensors wireless, that is composed by a great number of nodes which are micro-sensors Capable of collecting and transmitting data in an autonomous manner Figure 1 [1].

The sensor is a measuring instrument that transforms an observed physical or chemical quantity (temperature, humidity, acceleration, vibration, etc.) into an electrical signal, this transformation must be a reflection as perfect as possible of these quantities , In recent years the concept of intelligent sensor [3] (smart sensor), a system composed of several subsystems whose functions are distinct, combines between the acquisition of data (signal converter of the signal) , Information processing (microcontroller and memory), communication (radiofrequency), a location system (GPS) and an energy generator.

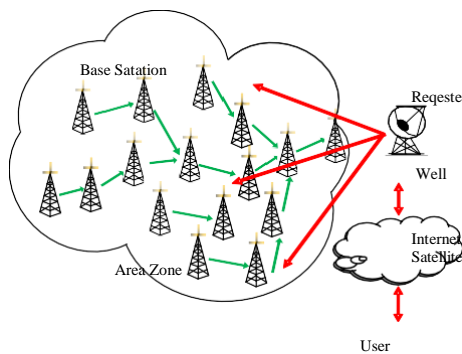

Figure 1. Wireless Sensor Network [1]

The energy consumption generally depends on the type of sensor and its deployment in its application, in order to design efficient solutions in energy, it is important to first analyze the various factors causing the dissipation of energy Of a sensor node which takes place in a general manner in several modes as it is consumed during the capture, processing and transmission (transmission, reception and listening of the channel), the latter is determined by the quantity The data to be communicated and the transmission distance, as well as by the physical properties of the radio module[3]. The emission of a signal is characterized by its power, when the transmission power is high, the signal will have a large range and the energy consumed will be higher, note

that the communication energy represents the largest portion of the energy consumed by a sensor node.

## III. PRINCIPLE OF BATTERY OPERATION (LITHIUM-ION)

Li-ion technology consists in using the electrochemical circulation of the lithium ion in two materials and at different potential values. The positive electrode and the negative electrode constitute the two redox potentials, and the potential difference creates the voltage within the battery. In use (the accumulator discharges), the negative electrode releases lithium in ionic form  $\text{Li}^+$ :  $\text{Li}^+$  ions migrate to the positive electrode via the ion conductive electrolyte; The passage of each  $\text{Li}^+$  ion within the accumulator is compensated by the passage of an electron in the external circuit, in the opposite direction: this is what creates the electric current making the noued work. Figures. 2 and 3 The shows des charing and the discharge digramme lithim-ion respectively [4]-[8].

Figure 4 describes the equivalent circuit of a lithium-ion battery or,  $E$  is the voltage of the battery without charge voltage;  $E_0$  is the idle voltage;  $K$  is the polarization constant or the polarization resistance; Maximum capacity of the battery;  $Q$  is the exponential tension;  $B$  is the exponential capacitance. All parameters of the equivalent circuit are based on the characteristic circuit in discharge.

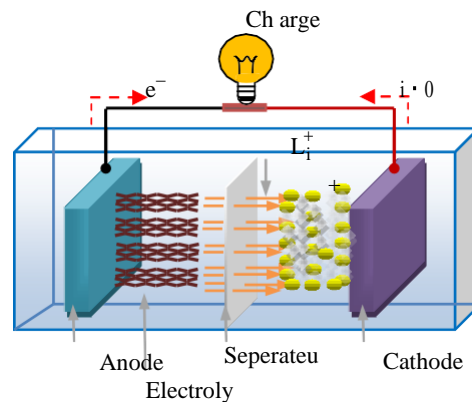

Figure 2. Diagram of a Lithium-Ion battery in discharge.

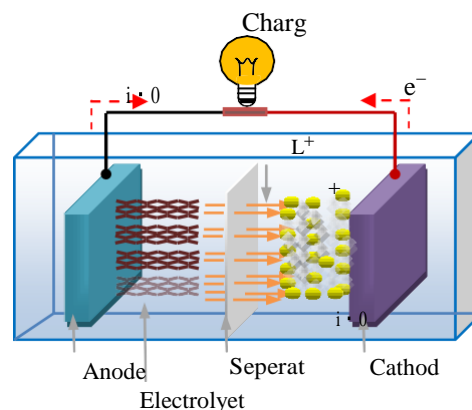

Figure 3. Diagram of charged lithium-ion battery.

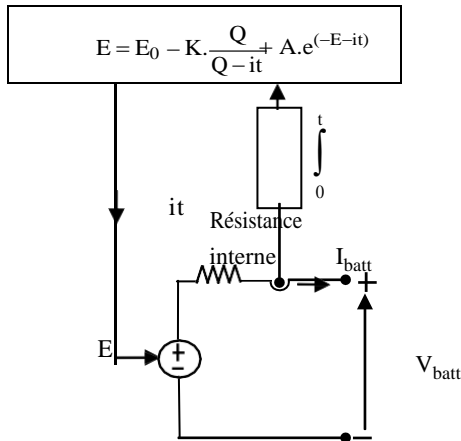

Figure 4. The equivalent circuit of a lithium-ion battery.

#### IV. THE BIDIRECTIONAL CONVERTER FOR WIRELESS SENSORLESS NETWORKS

The bidirectional converter changes the current flow direction of the battery according to the node power requirement. The BDC boosts up the battery voltage during the high power state and the start-up state. The BDC buck mode is activated for the battery charging state. The non-isolated PWM controlled power converter is selected for the BDC designing process.[9] The BDC circuit diagram is shown in Figure 5.  $V_{bat}$  is the battery voltage and the  $C_1$  is the LV side capacitor.  $L$  is denoted by the BDC inductor and  $Q_2$  and  $Q_3$  are MOSFET switches. The capacity of the DC bus capacitor bank is denoted by  $C_2$  [10]

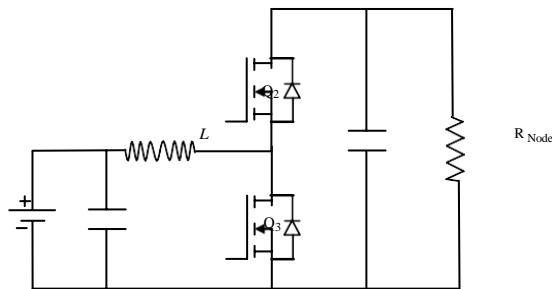

Figure 5 . Bidirectional converter circuit diagram.

When the energy flows from the LV to the HV side during the boost mode,  $Q_3$  operates as the active switch and the  $Q_2$  is passive switch. The BDC current flow diagram during the boost mode is shown in Figure 6. The BDC boost mode operation is similar to the UDC boost mode operation. The  $Q_2$  switch is operated as a diode[11].

Figure 7 shows the power flow during the buck operation. The  $Q_2$  switch is the active switch in the buck mode operation and the  $Q_3$  in the passive state. When the  $Q_2$  is ON state, the current flow from the HV side to the LV side and the energy is accumulated in the inductor. Figure 8 shows the power flow during the  $Q_2$  is OFF mode[9]-[12].

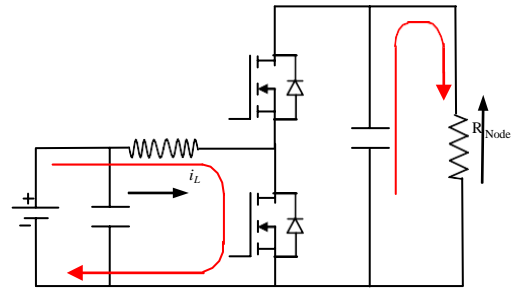

Figure 6. BDC current flow during the boost mod.

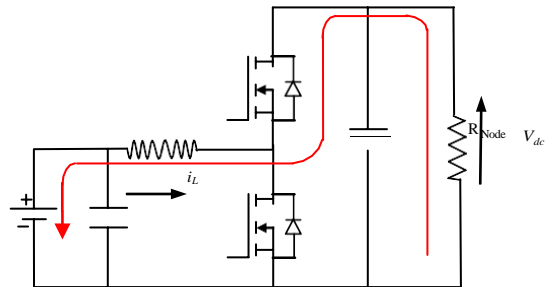

Figure 7. BDC during the  $Q_2$  ON state.

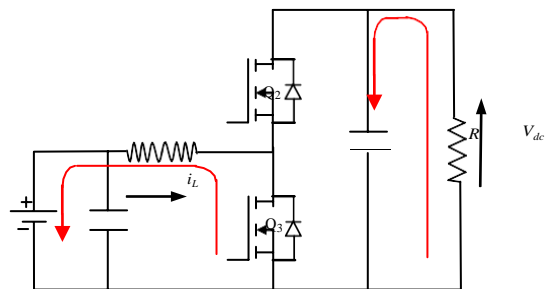

Figure 8. BDC during the  $Q_2$  OFF state

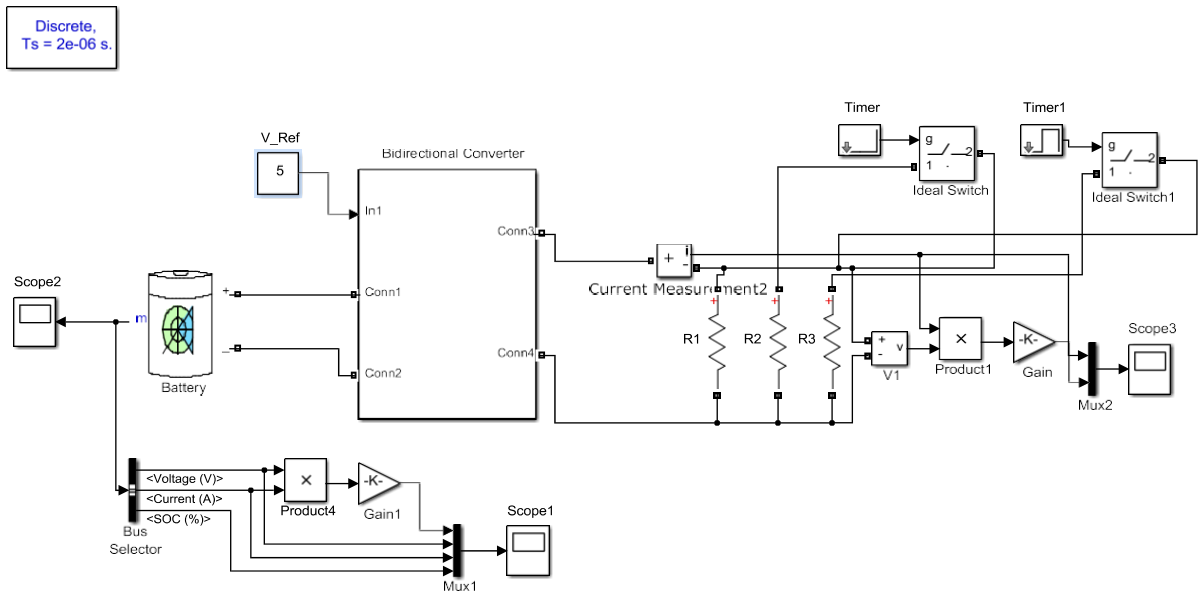

Figure 9. Model of wireless sensor Networks in MATLAB/Simulink.

V. SIMULATION RESULTS

.In order to characterize the behaviour of wireless sensor Networks, simulations were carried out using the model in Figure 9. This model uses a sensor node connecting to a lithium-ion battery through the DC-DC Buck Boost bidirectional converter that ensures an output constant voltage 5V. The following results were simulated in MATLAB / SIMULINK. And the simulation is divided into two cases, the first one present a performance test of Lithium-Ion for wireless sensor Networks and a second cases show the comparative studies between three battery technologies

Case 1: Lithium-Ion for wireless sensor Networks:

This case are divided by three phases topologies the first one stand for the beginning phase’s the wireless sensor Networks are in data acquisition and processing phase ( $P_{node}=10mW$ ). The second phase correspond to Listening to the transmission channel phase where the power is equal( $P_{node}=40mW$ ), and finally the wireless sensor Networks is in several transmission and reception of data phases , in this phase the node consumes more and more energy ( $P_{node}=60mW$ ), when the power constraints are illustrated in the Table 1 and Figure 10.

Table 1. Specified topology of wireless sensor networks .

Phases	Event information	Power [mW]
Phase 1	Acquisition	10
Phase 2	Processing	40
Phase 3	transmission	60

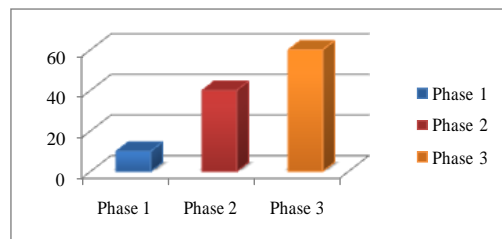

Figure 10. Energy consumption [mW] during the three phases.

The simulated results identified by Figure. 11 show the variations of the battery power, and Figures. 12 and 13 describe variation of current and voltage respectively in different scenarios. Figure 14 describe evaluation of state of charge during all seniors (it was initialized to 70 % at the beginning of the simulation). Figure 15 describe the battery duty cycle of bidirectional DC- DC converter.

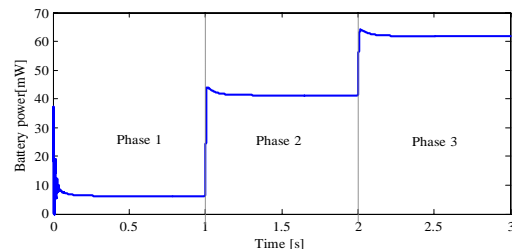

Figure 11. Variation of battery power in different phases

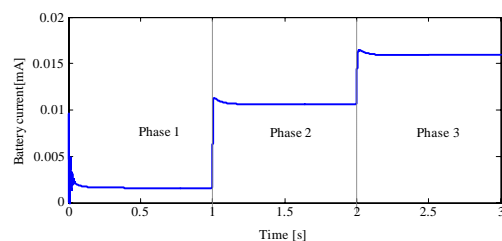

Figure 12 . Variation of battery current in different phases.

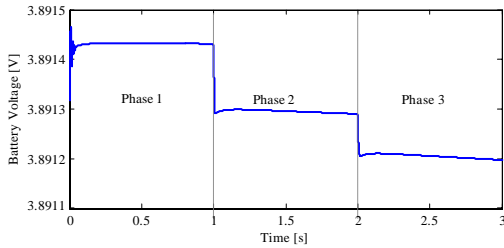

Figure 13 . Variation of battery voltage in different phases.

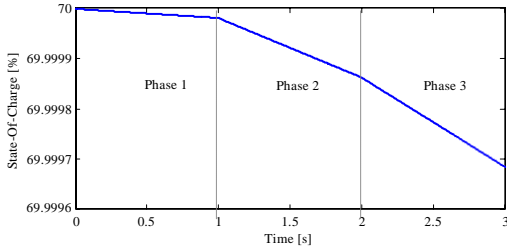

Figure 14. State of charge of battery in different phases.

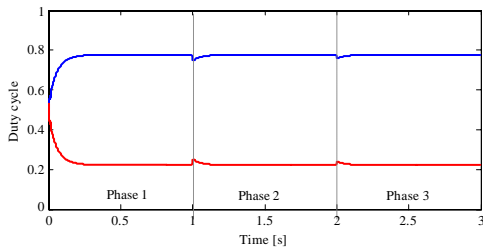

Figure 15. Duty cycle of bidirectional DC-DC converter in different cases.

Figure 16 and 17, demonstrate the variation of nodal power and nodal current correspondingly.

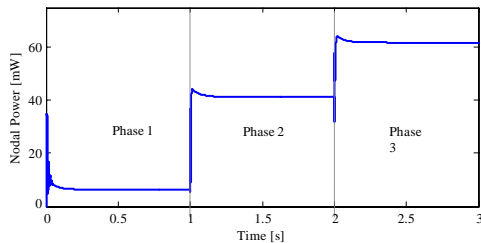

Figure 16 . Variation of nodal power in different phases.

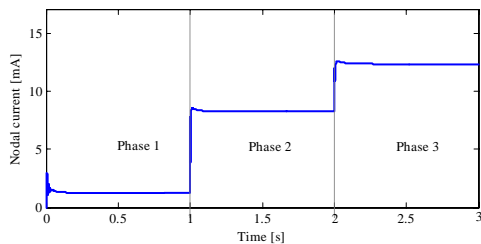

Figure 17. Variation of nodal current in different phases.

It is observed that the power and current nodal variation are almost the same variations in the different phases and form different battery technologies.

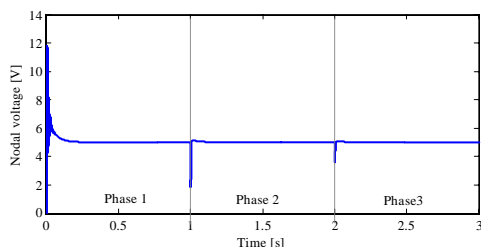

Figure 18. Variation of nodal voltage in different phases.

According to Figure. 10, the bidirectional DC-DC converter is tested by varying the output node resistor, the variation of the voltage in the node still remains around 5V Figure 18. The disturbances do not affect the performance of the buck-boost DC-DC converter output voltage.

*Case 2: Comparative studies:*

In the node the large energy consumption is during transmission, so a comparative study between the three types of stack will be more concrete during the third phase and one can observe a different observable in the representation of the state of charge of three types of battery technology as a function of time Figure 19, such as the rate of lithium battery Ion rapidly reduced than that of the Nickel Metal Hydride battery and itself as the Nickel Cadmium battery.

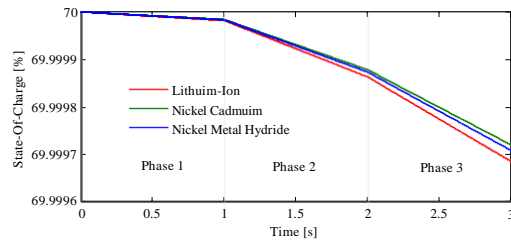

Figure 19. Comparative State of charge of different battery in different phases.

It is interesting to show the variation of SOC is inspired as a function of time equations for each type of battery Figure 18.

**Fiting formula for lithium Ion battery:**

$$SOC = 2e-006*t^{7} - 1.4e-005*t^{6} + 1.7e-005*t^{5} + 7.7e-005*t^{4} - 0.00026*t^{3} + 0.00023*t^{2} - 8.3e-005*t + 70 \quad (1)$$

**Fiting formula for Nickel Cadmium battery:**

$$SOC = 1.8e-006*t^{7} - 1.2e-005*t^{6} + 1.5e-005*t^{5} + 6.9e-005*t^{4} - 0.00023*t^{3} + 0.0002*t^{2} - 7.4e-005*t + 70 \quad (2)$$

**Fiting formula for Nickel Metal Hydride battery:**

$$SOC = 1.9e-006*t^{7} - 1.3e-005*t^{6} + 1.6e-005*t^{5} + 7.2e-005*t^{4} - 0.00024*t^{3} + 0.00021*t^{2} - 7.7e-005*t + 70 \quad (3)$$

These equations have allowed us to calculate the SOC rate for each type of battery at any time, in addition we note that there are small variations for each coefficient of variable x from one equation to another as in The ascending order of equation 2, equation 3 then equation 1, the battery Nickel Cadmium, Nickel Metal Hydride and then lithium Ion. It can be said that the Nickel Cadmium battery gives a slight improvement compared with other batteries, the equations (1), (2) and (3) given, and even the results of the table 2. The SOC value at the beginning and end of phase 3 demonstrated that the Nickel Cadmium battery is more cost effective for the sensor node against Nickel Metal Hydride and lithium Ion batteries

In the transmission phases, table 2 describe the change of SOC value of beginning and end of phase for each materiel battery type.

Table 2. Comparison SOC between three battery types in each start and end of the third phase.

Type	Phase 3		Diffrence
	Begin	End	
Lithui m-Ion	69.99987	69.99996	0.00018
Nickel Cadmium	69.99988	69.99972	0.00016
Nickem Metal Hydride	69.99989	69.99972	0.00017

According to the table above there is a difference between the beginning and the end of the phase for each battery type, so there is a addition energy consumption in the transmission phases, but variation was different from one type of battery to another In order from smallest to largest, the Nickel Cadmium battery, the Nickel Metal Hydride and then the lithium Ion.

The control of the bidirectional DC-DC converter, switching from one phase to another phase a peak power change at the end of each phase (1 and 2 respectively). Figures 20 and 21 shows that the Nickel Metal Hydride batteries present a less peak power compared with others batteries (Lithium Ion and Nickel Cadmium).

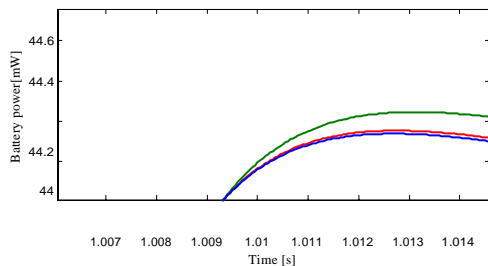

Figure 20. Comparative of peak power in different battery technologies at the end of treatment phases.

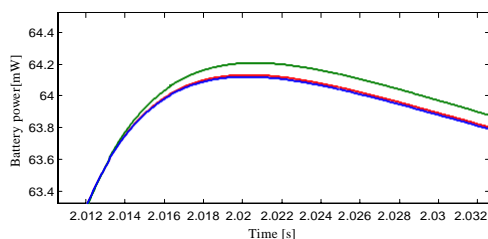

Figure 21. Comparative of peak power in different battery technologies at the end of transmission phases.

The exact values of the power peaks in mW inspired by the curves are given in Table 3 and their graphical representations respectively in Figures. 22 and 23, these values are classified in the order of lowest value to the highest of the Most suitable battery for our Nickel Metal Hydride node with 44.13mW in phase 1 to 2 and 64.10mW in phase 2 to 3 against the Lithium-Ion and Nickel Cadmium battery.

Table 3. Power comparison between three battery types in the end of the second phase.

Type	Pick of power [mW]	
	1	2
Lithium-Ion	44.15	64.11
Nickel Cadmium	44.25	64.21
Nickem Metal Hydride	44.13	64.10

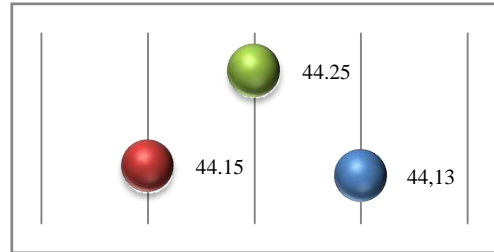

Figure 22. Power [mW] comparison between three battery types in the end of the seconde phase.

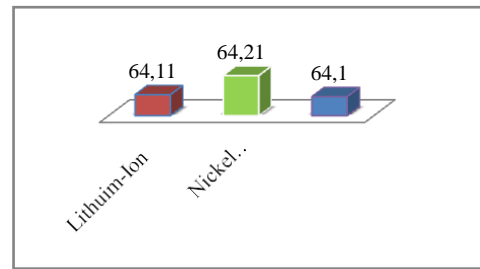

Figure 23. Power [mW] comparison between three battery types in the end of the therid phase.

In addition, the results of power peak variations in the sensor node of the end of phase 2 to3 and are given respectively in Figures. 22 and 23 and in table. show that the power peaks of the stacks Nickel Cadmium give poor results as the batteries and lithium Ion and Nickel Metal Hydride and lithium but with a more or less negligible differences of 0.12 mW that is to say without risk for our node.

Finally, the results of simulation of the discharges curves as a function of time for each type of battery technologies applied to a current of 100 mA and 200 mA respectively in Figures. 24 and 25 shows that the discharge of the lithium ion battery Is fast as the discharge of the Nickel Metal Hydride battery and that is even faster than the Nickel Cadmium battery.

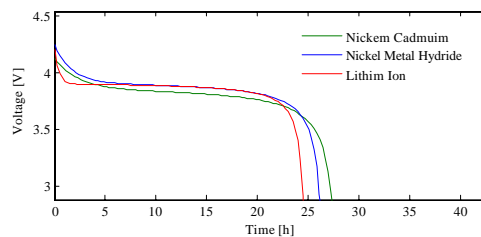

Figure 24. Discharge curve for 100 mA current.



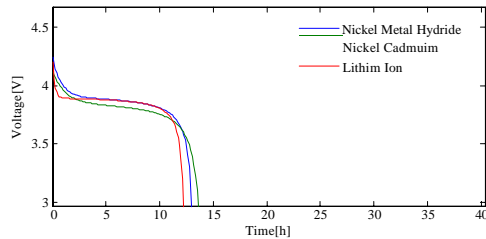

Figure 25. Discharge curve for 200 mA current.

Simulation results in Figures 24 and 25 prove that Nickel Cadmium batteries have a long discharge duration compared to Nickel Metal Hydride and Lithium-Ion batteries.

Due to the importance of the energy management problem in the wireless sensor networks and following all these assumptions it can be concluded that the Nickel Cadmium battery technology is the most suitable and battery candidate applied to the wireless sensor network node, a holistic approach to energy conservation in (WSNs) is essential. However, such an approach is still difficult to find due to the diversity of applications and differing requirements, such as techniques for optimizing energy consumption.

## VI. CONCLUSION

This study demonstrates the robustness of dynamic performance of bidirectional DC-DC converter for wireless sensor networks. In the present work, comparative studies of three battery technologies lithium-Ion Nickel Cadmium and Nickel Metal hydride are presented. Three fitting formula are proposed that permit the relationship between state of charge and the timing. Nickel cadmium is the battery candidate for wireless sensor networks compared with Lithium-Ion and Nickel metal battery technologies.

The power variation phases do not affect the performance of the bidirectional DC-DC converter. Moreover, the future industrial transmission and communication sector must take into consideration the paper results studies into design steps.

## REFERENCES

- [1] Mohd Fauzi Othmana, Khairunnisa Shazalib "Wireless Sensor Network Applications: A Study in Environment Monitoring System" International Symposium on Robotics and Intelligent Sensors Volume 41, 2012, Pages 1204-1210 2012
- [2] Joseph Polastre, Robert Szewczyk, Alan Mainwaring, David Culler, and John Anderson "ANALYSIS OF WIRELESS SENSOR NETWORKS FOR HABITAT MONITORING" chapitre 18 page 1 to 23 2004
- [3] S. E. Abdellaoui, Y. Fakhri, S. Saoudi et D. Aboutajdine, "Energy Efficiency of MIMO Cooperative Networks with Energy Harvesting Sensor Nodes", International Journal of Ad hoc, Sensor and Ubiquitous Computing (IJASUC), Vol.4, No.2 (2013).
- [4] [https://fr.wikipedia.org/wiki/Batterie\\_d%27accumulateurs](https://fr.wikipedia.org/wiki/Batterie_d%27accumulateurs) consulted 20-04-2017
- [5] Jia-Min S, Hung-Liang J, Jinn-Chang W, Kuen-Der W. "Single-phase three-wire grid-connected power converter with energy storage for positive grounding photovoltaic generation system". Electr Power Energy Syst 2014.

- [6] Ngok-Man Sze, Feng Su, Yat-Hei Lam, Wing-Hung Ki, and Chi-Ying Tsui. Integrated single-inductor dual-input dual-output boost converter for energy harvesting applications. In Circuits and Systems, 2008. ISCAS 2008. IEEE International Symposium on, pages 2218–2221, 2008.
- [7] Ko Ko Win, Xinhui Wu, S. Dasgupta, Wong Jun Wen, R. Kumar, and S.K. Panda. Efficient solar energy harvester for wireless sensor nodes. In Communication Systems (ICCS), 2010 IEEE International Conference on, pages 289–294, nov. 2010
- [8] B. Gasbaoui, A.Nasri, A.Laoufi and Y.f Mouloudi. "4 WD Urban Electric Vehicle Motion Studies Based on MIMO Fuzzy Logic Speed Controller", International Journal of Control and Automation Vol. 6, No. 1, February, 2013 105.
- [9] Anasuya. N. Jadagerimath, Battery Capacity Management in Wireless Sensor Network Rechargeable Sensor Nodes International Journal Of Engineering And Computer Science ISSN:2319-7242 Volume - 3 Issue -9 September, 2014 Page No. 8129-8135.
- [10] B. Khiari, A. Sellami and R. Andoulsi, "MPPT Control Of Photovoltaic Pumping System Based on Discrete Sliding Mode", International Renewable Energy Congress, pp. 66 – 72, Sousse, Tunisie, November 5-7, 2010.
- [11] E. Benkhilil et A. Gharbi, "Modélisation et Simulation d'un Générateur Photovoltaïque avec un Etage d'Adaptation DC/DC", The First International Conference on Energy and Sustainable Development, ICESD'2011, 29-30 November 2011, University of Adrar, Algeria.
- [12] Anane, R., K. Raoof, et al. (2015). "On the Evaluation of GMSK Scheme with ECC Techniques in Wireless Sensor Network." arXiv preprint arXiv:1505.05755.

## ACKNOWLEDGMENT

The authors would like to thank the laboratory of energy in arid region (ENERGARID) Bechar University and laboratory of smart grids & renewable energy (SGRE) faculty of technology, department of electrical Engineering, Tahri Mohamed university Bechar Algeria.

### LITHIUM-ION PARAMETER

NOMINAL VOLTAGE	3.6 V
RATED CAPACITY	2500e-3 Ah
INITIAL STATE OF CHARGE	70%
INTERNAL RESISTANCE	0.0144 $\Omega$

## BIOGRAPHY



**Boubakeur Hamili** received the Diplôme of computer engineer from the University ES-SENIA of ORAN - Algeria in 1993 and the Master degree of computing and mathematical sciences in 2012 from Tahri Mohamed Bechar University - Algeria, and in 2016 PhD student in Laboratory of Energy in Arid Region (ENERGARID) Tahri Mohamed

Bechar University, Algeria has done his research in Energy management in wireless sensor networks in the Faculty of technology, Department of Electrical Engineering, Tahri Mohamed Bechar University.

*e-mail address:* boubakeur.adel@yahoo.fr



**Khelifa Benahmed** has done his research for Ph.D. degree in the field of sensor networks wireless at the school of computing and mathematical sciences at Liverpool John Moores University, UK. He has 26 years of experience in education and research at the University Tahri Mohamed Bechar,

Algeria. Khelifa has also several international publications in the fields: wireless sensor networks, security, surveillance, smart grid, Internet of things, and smart irrigation. Khelifa holds Engineer, Magister degrees and PhD in Computer sciences in University of Oran Algeria.

*e-mail address:* benahmed\_khelifa@yahoo.fr,



**Brahim Gasbaoui** received the electrical engineering diploma from the University Ibn-Khaldoun of TIARET (UIT) Algeria, in 1993 and the MS degree in 2008 from Bechar University - Algeria, and the Ph.D. degree from the Faculty of the Sciences and the Technology of the Bechar University Currently ,in 2017 professor degree

management, and Artificial and intelligence system optimisation.

*e-mail address:* gasbaoui\_2009@yahoo.com

He is a Professor of electrical engineering at Bechar University. His research interests include power electronics robust control for electric vehicle and propulsion system, power electronics, antilock brake systems, anti-skid control for electric vehicles drive, power