

Design of a Fuzzy Logic Controller For PV Applications

L. Rachedi^{#1}, C.Fetha^{#2}, T Bahi^{#3} and H. Bouzeria^{#4}

Dept. of Electrotechnic, Engineering Science Faculty
^{#1,2,3} Hadj Lakhdar university of Batna
 Batna, Algeria

¹nouflot@yahoo.fr - ²cfetha@yahoo.fr - ⁴bhamza23000@gmail.com

Dept. of Electrotechnic Engineering Science Faculty
^{#4} Badji Mokhtar university of Annaba
 Annaba, Algeria
³tbahi@hotmail.com

Abstract— this paper presents a new smart method of peak power point tracking for photovoltaic systems based by Design Fuzzy Logic Controller (FLC) for DC-to-DC Converters. The proposed FLC controller is based the fuzzy control algorithm and able to robust control and the response characteristics of FLC method according to the environment variation. The design of fuzzy controller modeled using Matlab/Simulink, with The Converter models for simulation are designed for the boost and buck modes of PV system .The results are analyzed and compared to those of the expected ideal operation to confirm the validity of the models.

Keywords— Photovoltaic systems, Design Fuzzy Logic Controller, DC-to-DC converter, boost and buck converter, PV system, Matlab/Simulink

I. INTRODUCTION

The photovoltaic panel is a power source whose parameters depend on some external factors like incident light angle, shading, ambient temperature etc. The Photovoltaic systems are always associated with some control and power electronics. Generally, more complex power electronic converters are needed in order to adapt the electrical frequency and voltage level to the planned use. In addition, the rational use of photovoltaic systems is possible only in association with power electronic converters in order to adjust the voltage of the photovoltaic array to the maximum power point independently of the output voltage of the system [1]. According to this position, the power transferred to the load can be only a fraction of the power that panel can supply at MPP. To correct this unbalance and prevent the associated lose of usefully power, some methods, generically named MPPT (Maximum Power Point Tracking) are used. A DC-to-DC converter serves the purpose of transferring maximum power from the solar PV module to the load. A DC-to-DC converter acts as an interface between the load and the PV module as shown in Figure 1. By changing the duty cycle the load impedance as seen by the source is varied and matched at the point of the peak power with the source so as to transfer

the maximum power [2]. The purpose of this paper is to study and compare advantages, execution efficiency for two type of DC-to-DC converter; boost converter and buck converter are most traditional converter used with MPPT methods, including fuzzy control Design methods. The FLC Method of MPPT is described here.

Matlab/Simulink is used in this paper to implement the modeling and simulations tasks, and to compare execution efficiency for the selected MPPT methods.

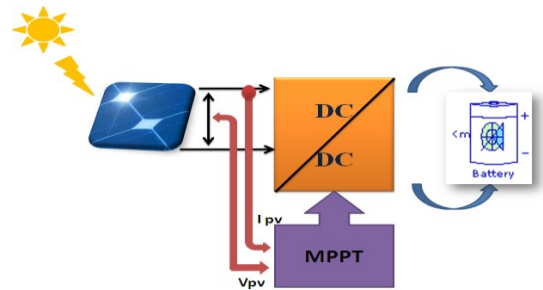

Fig.1 Chain of photovoltaic's with DC / DC converter controlled by an MPPT control of DC load

II. PAGE LAYOUT

The operation of a photovoltaic module is described by the "standard" model with a diode, established by Shokley for a single PV cell is generalized to a PV module by considering it as a set of identical cells connected in series or in parallel [3]. It takes into account not only the loss of tension expressed by the series resistance R_s , but also leakage currents expressed by a parallel resistance R_p (Fig.2).

The current-voltage characteristic describing the operation of the above circuit is given by the equation:

$$I = I_{ph} - I_s \left(e^{\frac{v+R_s I}{mV_T}} - 1 \right) - \frac{V + R_s I}{R_p} \quad (1)$$

Where:

- I_{ph} : photo current;
- I_s : reverse saturation current of the diode;
- m : ideality factor of the diode, $m = 1 \dots 5$;
- V_T : thermal voltage;
- K : Boltzmann constant;
- T : absolute temperature, $[T] = K$ (kelvin);
- e : charge of an electron.

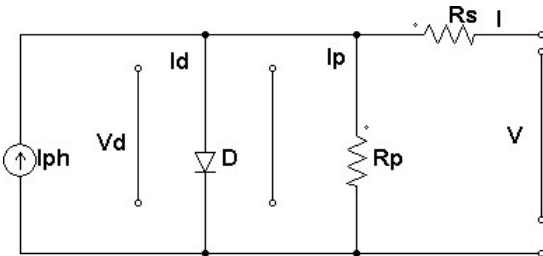

Fig.2 Equivalent circuit model of a PV cell with a diode

La figure 3 illustre de schéma bloc du programme en Simulink du modèle de la cellule PV.

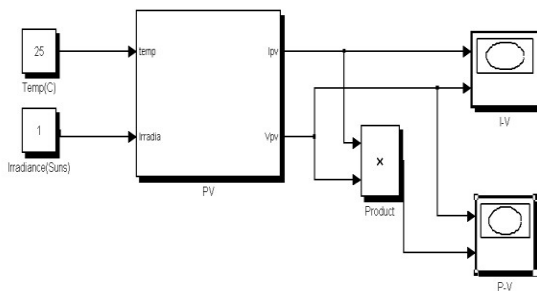

Fig. 3 Model Simulink de la cellule PV

For a PV module with I-V and P-V output characteristics of generalized PV model for a cell. The nonlinear nature of PV cell is apparent as shown in the Fig.4 and fig. 5; the output current and power of PV module depend on the cell's terminal operating voltage and temperature, and solar isolation as well.

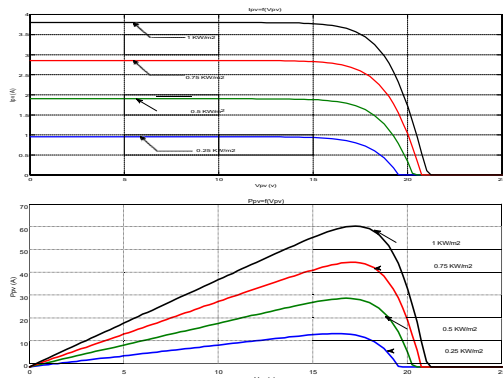

Fig.4 Simulink model I-V and P-V curves which is influenced by insolation when the cell temperature is constant at 25°C

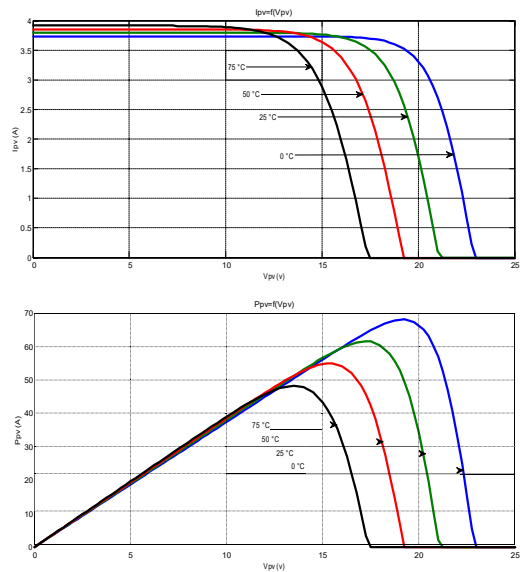

Fig.5 Simulink model I-V and P-V curves which is influenced by cell temperature when the insolation is constant at 1000 W/m²

III. DC-DC CONVERTERS

In most common applications, the MPPT is a DC-to-DC converter controlled through a strategy that allows imposing the photovoltaic module operation point on the Maximum Power Point (MPP) or close to it. On the literature, many studies describing techniques to improve MPP algorithms were published [4], permitting more velocity and precision of tracking. On the other hand, there is no a theory to guide the designer to choose, among the DC-to-DC converters family, the best one to operate as MPPT, thus, in most cases, the designers are tempted to use the simplest DC-to-DC converters – namely buck converter or boost converter[5]-[6].

A. The Buck Converter

The buck converter (Fig. 6) can be often found in the literature as the step-down converter. This gives a hint of its typical application of converting its input voltage into a lower output voltage, where the conversion ratio $M = V_o/V_i$ varies with the duty ratio D of the switch [7].

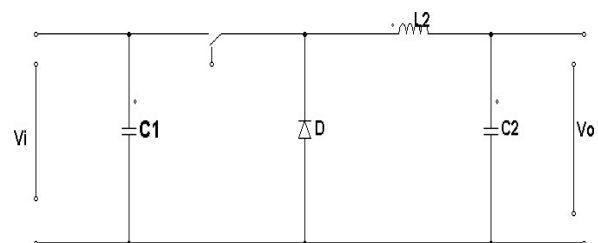

Fig.6 Ideal buck converter circuit

B. The Boost Converter

The boost converter, as shown in Fig. 7, is also known as the step-up converter. The name implies its typical application of converting a low input-voltage to a high output-voltage, essentially functioning like a reversed buck converter [8].

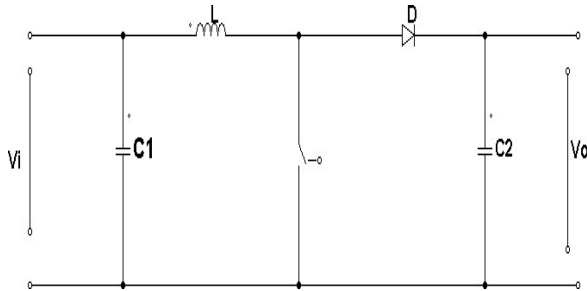

Fig.7 Ideal boost converter circuit

IV. MAXIMUM POWER POINT TRACKING

Maximum Power Point tracking controller is basically used to operate the Photovoltaic modules in a manner that allows the load connected with the PV module to extract the maximum power which the PV module capable to produce at a given atmospheric conditions. PV cells have a single operating point where the values of the current and voltage of the cell result in a maximum power output. With the varying atmospheric condition and because of the rotation of the earth, the irradiation and temperature keeps on changing throughout the day. So it is a big challenge to operate a PV module consistently on the maximum power point and for which many MPPT algorithms have been developed [9]. The most popular among the available MPPT techniques is fuzzy method.. The aim of the present work is to develop the simulink model of fuzzy MPPT controller has introduced on it to improve its overall performance [10].

A. Fuzzy Logic Controller Design

The fuzzy algorithm can make human knowledge into the rule base to control a plant with linguistic descriptions. It relies on expert experience instead of mathematical models. The advantages of fuzzy control include good popularization, high faults tolerance, and suitable for nonlinear control systems. A fuzzy controller design has four parts, fuzzification, control rule base, fuzzy inference, and defuzzification. The block diagram of the fuzzy control system is shown in Fig. 7[11].

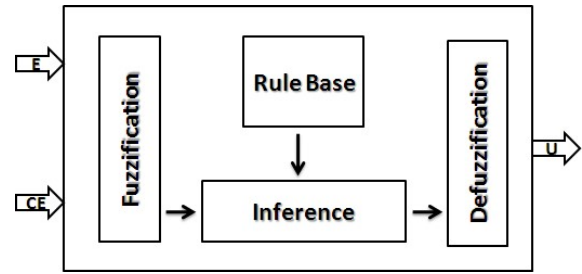

Fig.8 Block diagram of the fuzzy control.

- 1) *Fuzzification*: which converts controller inputs into information that the inference mechanism can easily uses to activate and apply rules.
- 2) *Rule-Base* :(a set of If-Then rules), which contains a fuzzy logic quantification of the expert's linguistic description of how to achieve good control.
- 3) *Inference Mechanism*: (also called an -inference enginel or -fuzzy inferencel module), which emulates the expert's decision making in interpreting and applying knowledge about how best to control the system
- 4) *Defuzzification Interface*: This converts the conclusions of the inference mechanism into actual inputs for the process.

FLC has two inputs which are: error and the change in error, and one output feeding to the pulse width modulation to control the DC-to-DC converter. The two FLC input variables error E and change of error CE at sampled times k defined by:

$$Error(k) = \frac{P(k) - P(k-1)}{V(k) - V(k-1)} \quad (2)$$

$$Change_Error(K) = Error(k) - Error(k-1) \quad (3)$$

Where P (k) is the instant power of the photovoltaic generator The input error (k) shows if the load operation point at the instant k is located on the left or on the right of the maximum power point on the PV characteristic, while the input CE (k) expresses the moving direction of this point. The fuzzy inference is carried out by using Mamdani method, FLC for the Maximum power point tracker. FLC contains three basic parts: Fuzzification, Base rule, and Defuzzification.

A.1 Fuzzification

The fuzzification stage converts real number input values into fuzzy values, the fuzzy inference engine processes the input data and computes the control outputs using IF and THEN rules. Figure 8 illustrates the fuzzy set [12].

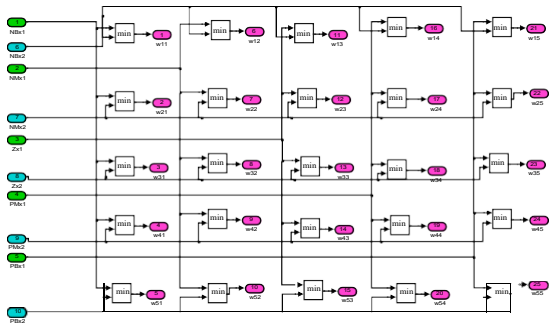

Fig. 9 The Simulink model of the Fuzzification process

A.2 Rule base

The knowledge base defining the rules for the desired relationship is between the input and output variables in terms of the membership functions. The control rules are evaluated by an inference mechanism, and represented as a set of: IF Error is ... and Change of Error is ... THEN the output will ...

The linguistic variables used are:

- NB:** Negative Big.
- NM:** Negative Medium.
- ZE:** Zero.
- PM:** Positive Medium.
- PB:** Positive Big.

Each fuzzy subset is represented by a triangular membership function as shown in the Fig.10; the Boolean operator --minll is used for the verbal connector --andll to simulate the input space of the rules

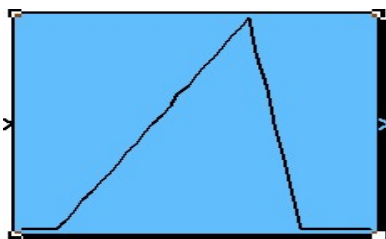

Fig.10 triangular membership function

A.3 Defuzzification

A defuzzification interface converts the conclusions of the inference mechanism into the crisp inputs for the process.

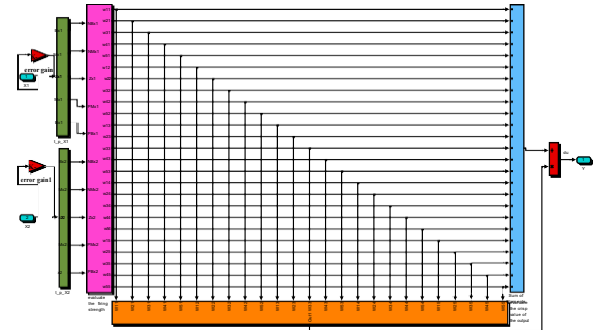

Fig. 11 The process from fuzzification to defuzzification in the FLC bloc

V. MPPT FUZZY CONTROLLER DESIGN SIMULATION

The designed fuzzy controller can be connected between PV module and DC-to-DC converter module to track the MPP. The output, voltage, current and power is the main comparison to take into consideration [13].

Therefore the min operator in Simulink Block Library is used to model the input spaces of 25 rules used by FLC. The outputs of the --minll operators indicate the strength of the rules in the output.

The triangular membership function is used to fuzzify the error and change-error. The error and change-errors are mapped between -1 and +1 on the universe of discourse. Simulation model for defuzzification and reasoning is depicted [14]-[15]. Fig.12 and Fig.14 take an insolation of 1000 and temperature 25 as initial value.

For Buck converter with Mpp Fuzzy Control as shown in Fig.12

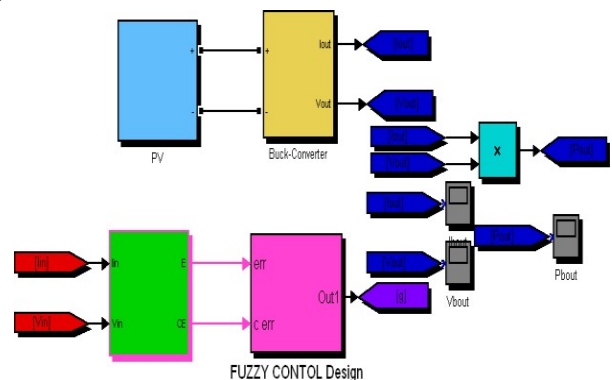

Fig.12 Block simulation of Buck converter with mpp Fuzzy Control Design

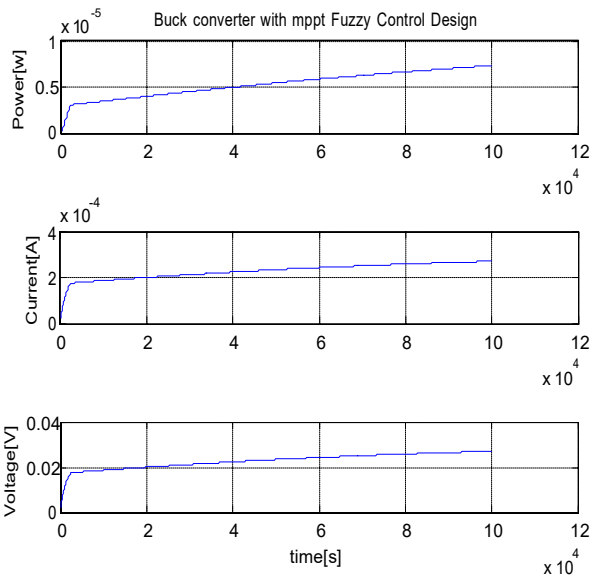

Fig.13 Output Power, current and voltage for Buck converter with fuzzy Controller Design

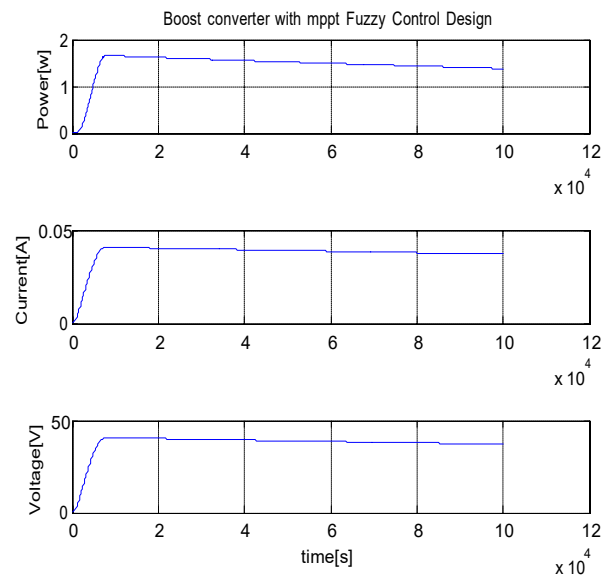

Fig.15 Output Power, current and voltage for Boost converter with fuzzy Controller Design

And for Boost converter with Mppt Fuzzy Control as shown in Fig.14

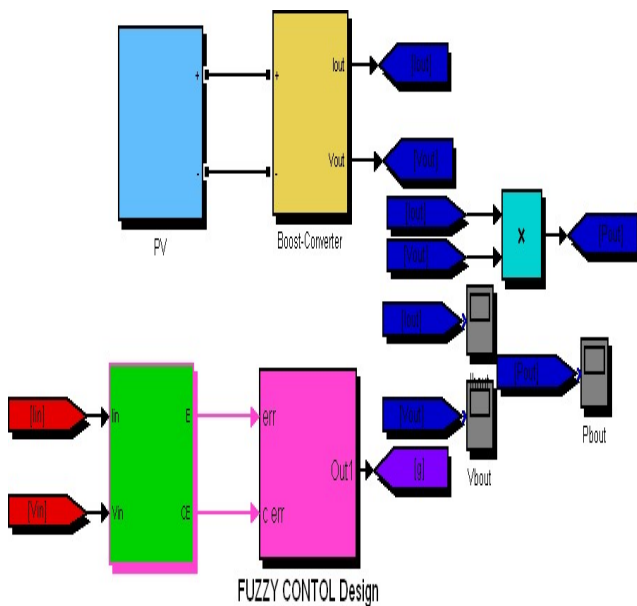

Fig.14 Block simulation of Boost converter with Mppt Fuzzy Control Design

VI. CONCLUSIONS

In this paper we are focus on comparison of two different Converters which will connect with the fuzzy controller. Because maximizing energy generation from solar energy has become highly interested. One popular way to maximize the PV generation is use of MPPT and DC-to-DC converter. The fuzzy logic controller design on control buck converter and boost converter by using Simulink has been successfully achieved. It is confirmed that the DC-to-DC converter gives a value of output voltage exactly as circuit requirement. These studies could solve many types of problems regardless on stability because as we know that fuzzy logic controller is an intelligent controller to their appliances.

REFERENCES

- [1] R.Djamil;M.Ernest, Optimization of Photovoltaic Power Systems Modelization, Simulation and Control, London: Springer-Verlag, 2012.
- [2] U,Dhanapala,C.H.Wickramasinghe, Extraction of parameters for simulating photovoltaic panels, 6th IEEE International Conference on Industrial and Information Systems (ICIIS), pp.539-544, 16-19 Aug.2011.
- [3] N. Kishor, M. Gradella Villalva, and. S. Ranjan, Modeling of PV Module with Consideration of Environmental Factors *Member, IEEE. Ernesto Ruppert, 2010.*
- [4] S. Yuvarajan, Dachun Yu, Shanguang Xu, A novel power converter for photovoltaic applications, Journal of Power Sources, Elsevier Science, Vol. 135, pp. 327-331, 2004.
- [5] Solodovnik E.V., Shengyi Liu, Dougal R.A., — Power controller design for maximum power tracking in solar installationsl, J Trans Power Electron, 2004, Vol. 19(5), pp. 1295-1304.

- [6] Roberto F. Coelho, Filipe, A Study of Basic DC-to-DC Converters Applied in Maximum Power Point Tracking, Proceedings of IEEE Conference, pp. 673-677, 2009.
- [7] T.S.USTUN and S. Mekhilef, Effects of a Static Synchronous Series Compensator (SSSC) Based on Soft Switching 48 Pulse PWM Inverter on the Power Demand from the Grid, Journal of Power Electronics, vol. 10, pp. 85-90, 2010.
- [8] Hairul, Zainudin, S, Mekhilef, Comparison Study of Maximum Power Point Tracker Techniques for PV Systems; 14th International Middle East Power Systems Conference (MEPCON'10), Cairo University, Egypt, December 19-21, 2010.
- [9] K.Kachhiya, M Lokhande MATLAB/Simulink Model of Solar PV Module and MPPT Algorithm, National Conference on Recent Trends in Engineering & Technology 13-14 May 2011.
- [10] A.Panda, M.K.Pathak, Fuzzy Intelligent Controller for the Maximum Power Point Tracking of a Photovoltaic Module at Varying Atmospheric Conditions; Journal of Energy Technologies and Policy, Vol.1, No.2, 2011.
- [11] K. Passino and S. Yurkovich, Fuzzy Control, Addison Wesley, 1998
- [12] Sung-Jun Kang, Jae-Sub Ko, Jung-Sik Choi, Mi-Geum Jang, Ju-Hui Mun, Jin-Gook Lee, Dong-Hwa Chung, -A Novel MPPT Control of photovoltaic system using FLC algorithm, 11th Int. Conf. on Cont. Auto. and Syst., Oct. 26-29, 2011, pp.434-439.
- [13] Pongsakorn Takun, ; Maximum Power Point Tracking using Fuzzy Logic Control for Photovoltaic System. IMECS2011_pp986-990, hong-kong
- [14] H. Altas, and A.M. Sharaf, A Novel GUI Modeled Fuzzy Logic Controller for a Solar Powered Energy Utilization Scheme, 13th International Conference on Emerging Nuclear Energy Systems, June 3-8, 2007, Turkey.
- [15] M. A. Usta, Ö. Akyazı, " Design and Performance of Solar Tracking System with Fuzzy Logic Controller", 6th International Advanced Technologies Symposium, 16-18 May 2011, Turkey.